

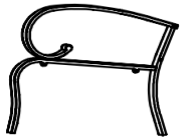





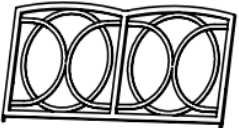
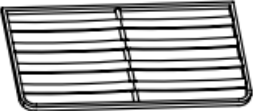

## SAVE THESE INSTRUCTIONS

### SONOMA CLAREMONT LOVESEAT CHAT SET ASSEMBLY INSTRUCTIONS ASSEMBLE ON A FLAT, PROTECTED SURFACE.

PART LIST	FIGURE	QUANTITY	DESCRIPTION
A		1 PC	RIGHT ARM
B		1 PC	LEFT ARM
C		1 PC	BACK
D		1 PC	SEAT
E		6 PCS + 1 PC	FLAT WASHER + SHORT BOLT (M6*20MM)
F		2 PCS + 1 PC	FLAT WASHER + LONG BOLT (M6*40MM)
G		1 PC	ALLEN WRENCH
H		2 PCS	BACK CUSHION
I		1 PC	SEAT CUSHION

FOR MISSING OR INCORRECT PARTS/HARDWARE, CONTACT THE MANUFACTURER'S CUSTOMER SERVICE DIRECTLY AT  
1-866-905-4107 OR [WWW.YOTRIOINT.COM](http://WWW.YOTRIOINT.COM)  
REFER TO LAST PAGE FOR ADDITIONAL CUSTOMER SERVICE DETAILS.

**ASSEMBLY INSTRUCTIONS (CONTINUED)**  
**SONOMA CLAREMONT LOVESEAT CHAT SET ASSEMBLY INSTRUCTIONS**

**STEP 1**

A. PLACE SEAT (D) ON A FLAT PROTECTED SURFACE WHILE HOLDING IT ON ITS SIDE AS SHOWN.

B. CONNECT RIGHT ARM (A) TO SEAT (D) WITH FLAT WASHERS AND SHORT BOLTS (E) USING ALLEN WRENCH (G). DO NOT TIGHTEN COMPLETELY.

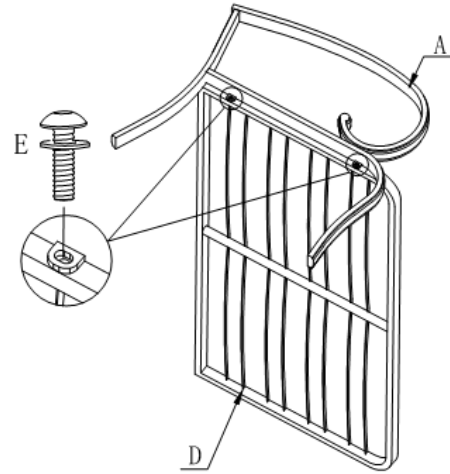

**STEP 2**

A. ROTATE ASSEMBLED UNIT TO HAVE RIGHT ARM ON FLAT, PROTECTED SURFACE.

B. CONNECT LEFT ARM (B) TO SEAT (D) WITH FLAT WASHERS AND SHORT BOLTS (E) USING ALLEN WRENCH (G). DO NOT TIGHTEN COMPLETELY.

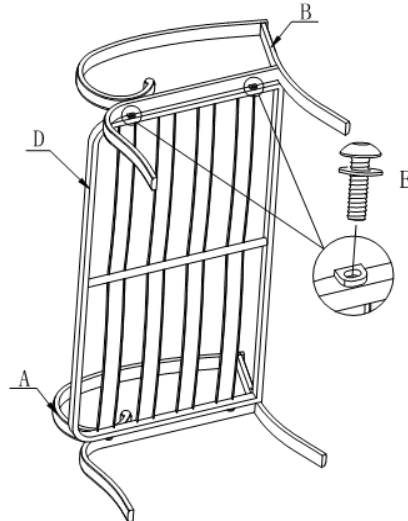

**STEP 3**

A. ROTATE ASSEMBLED UNIT TO THE STANDING POSITION.

B. CONNECT BACK (C) TO RIGHT ARM (A) AND LEFT ARM (B) WITH FLAT WASHERS AND SHORT BOLTS (E), FLAT WASHERS AND LONG BOLTS (F) USING ALLEN WRENCH (G). DO NOT TIGHTEN COMPLETELY.

C. COMPLETELY TIGHTEN ALL BOLTS WITH ALLEN WRENCH (G) FROM STEPS 1 THROUGH 3.

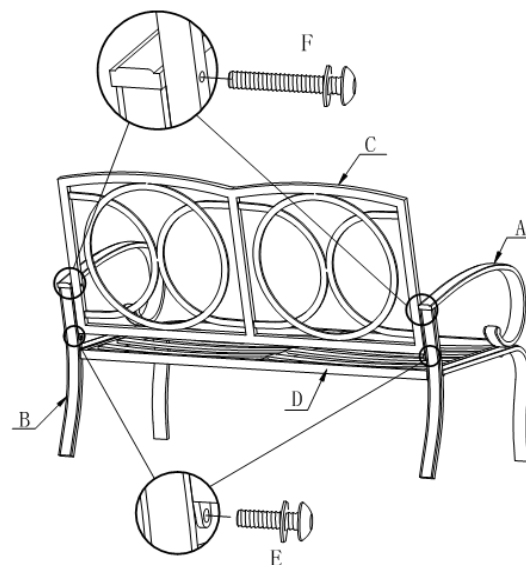

**ASSEMBLY INSTRUCTIONS (CONTINUED)**  
**SONOMA CLAREMONT LOVESEAT CHAT SET ASSEMBLY INSTRUCTIONS**

**STEP 4**

A. PLACE SEAT CUSHION (I) ON LOVESEAT AND ATTACH TIES TO BACK CROSSBAR.

B. PLACE BACK CUSHION (H) ON LOVESEAT.

C. ASSEMBLY IS COMPLETE.

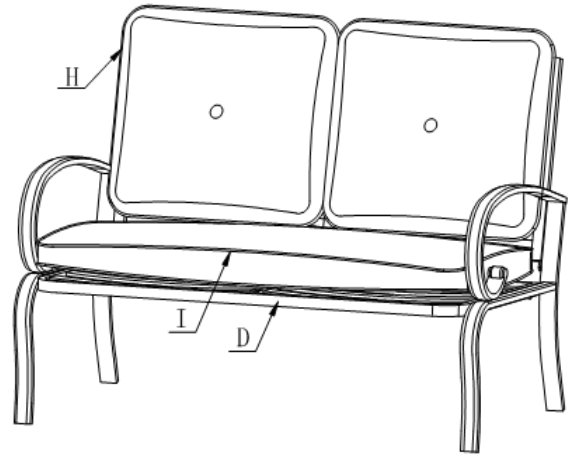

**\*\* WE RECOMMEND THAT YOU SAVE THE ALLEN WRENCH AND PERIODICALLY TIGHTEN ALL BOLTS.**

**WEIGHT LIMIT**

LOVESEAT: 500 LBS

**CARE AND CLEANING**

FRAME: WIPE CLEAN WITH A MILD SOAP AND WATER SOLUTION, RINSE WITH CLEAN WATER, AND DRY THOROUGHLY.

CUSHION: SPOT CLEAN WITH A SOFT, DAMP CLOTH.

DO NOT STAND OR CLIMB ON LOVESEAT.

IN ORDER TO PROLONG THE LIFE OF YOUR LOVESEAT, PLEASE STORE IN DRY SHELTERED PLACE WHEN NOT IN USE OR DURING INCLEMENT WEATHER.

**WARRANTY**

1 YEAR LIMITED WARRANTY FOR FRAME AND CUSHIONS.

CUSTOMER SERVICE: PLEASE NOTE - DO NOT RETURN THIS ITEM TO THE RETAILER.

CUSTOMER SERVICE HOT LINE: 1-866-905-4107





SERVICE HOURS: 11:30 A. M. to 8:00 P. M. EASTERN STANDARD TIME /8:30 A. M. to 5:00 P. M. PACIFIC STANDARD TIME

WEBSITE: WWW.YOTRIOINT.COM

TO ASSIST YOU BETTER, PLEASE GATHER THE FOLLOWING INFORMATION BEFORE CALLING CUSTOMER SERVICE:  
PRODUCT NAME AND STYLE NUMBER, DESCRIPTION AND OR IMAGES OF THE ISSUE, ORIGINAL STORE PURCHASE RECEIPT.

## SAVE THESE INSTRUCTIONS

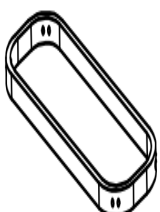
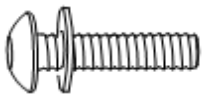
### SONOMA CLAREMONT COFFEE TABLE CHAT SET ASSEMBLY INSTRUCTIONS ASSEMBLE ON A FLAT, PROTECTED SURFACE.

PART LIST	FIGURE	QUANTITY	DESCRIPTION
A		1 PC	TOP
B		4 PCS	LEG
C		1 PC	LEG CONNECTOR
D		12 PCS + 1 PC	FLAT WASHER + BOLT (M6*28MM)
E		1 PC	ALLEN WRENCH

FOR MISSING OR INCORRECT PARTS/HARDWARE, CONTACT THE MANUFACTURER'S CUSTOMER SERVICE DIRECTLY AT  
1-866-905-4107 OR [WWW.YOTRIOINT.COM](http://WWW.YOTRIOINT.COM)  
REFER TO LAST PAGE FOR ADDITIONAL CUSTOMER SERVICE DETAILS.

**ASSEMBLY INSTRUCTIONS (CONTINUED)**  
**SONOMA CLAREMONT COFFEE TABLE CHAT SET ASSEMBLY INSTRUCTIONS**

**STEP 1**

A. PLACE TOP (A) UPSIDE DOWN ON A FLAT, PROTECTED SURFACE.

B. ATTACH LEGS (B) TO TOP (A) WITH FLAT WASHERS AND BOLTS (D) USING ALLEN WRENCH (E). DO NOT TIGHTEN COMPLETELY.

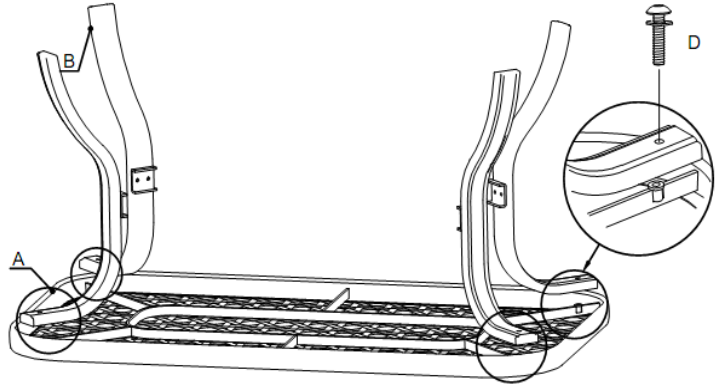

**STEP 2**

A. ATTACH LEG CONNECTOR (C) TO LEGS (B) WITH FLAT WASHERS AND BOLTS (D) USING ALLEN WRENCH (E). DO NOT TIGHTEN COMPLETELY.

B. TIGHTEN COMPLETELY ALL BOLTS ON LEG CONNECTOR (C) FIRST THEN AT TOP (A) WITH ALLEN WRENCH (E).

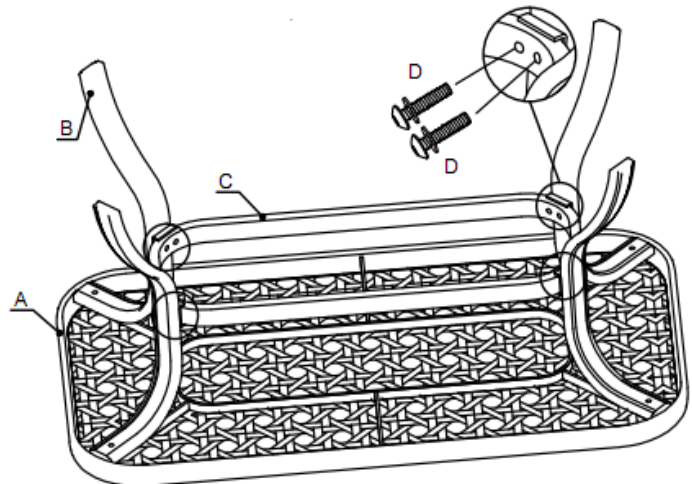

**ASSEMBLY INSTRUCTIONS (CONTINUED)**  
**SONOMA CLAREMONT COFFEE TABLE CHAT SET ASSEMBLY INSTRUCTIONS**

**STEP 3**

A. ROTATE TABLE TO THE UPRIGHT POSITION.

B. ASSEMBLY IS COMPLETE.

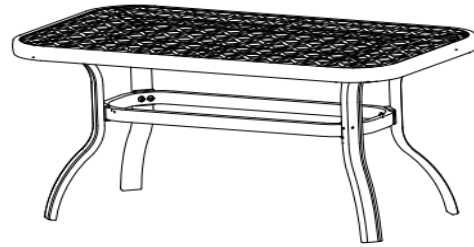

**\*\* WE RECOMMEND THAT YOU SAVE THE ALLEN WRENCH AND PERIODICALLY TIGHTEN ALL BOLTS.**

**WEIGHT LIMIT**

COFFEE TABLE: 165 LBS

**CARE AND CLEANING**

FRAME: WIPE CLEAN WITH A MILD SOAP AND WATER SOLUTION, RINSE WITH CLEAN WATER, AND DRY THOROUGHLY. DO NOT SIT, STAND, OR CLIMB ON TABLE.

IN ORDER TO PROLONG THE LIFE OF YOUR TABLE, PLEASE STORE IN DRY SHELTERED PLACE WHEN NOT IN USE OR DURING INCLEMENT WEATHER.

**WARRANTY**

1 YEAR LIMITED WARRANTY FOR FRAME AND CUSHIONS.

CUSTOMER SERVICE: PLEASE NOTE - DO NOT RETURN THIS ITEM TO THE RETAILER.

CUSTOMER SERVICE HOT LINE: 1-866-905-4107

SERVICE HOURS: 11:30 A. M. to 8:00 P. M. EASTERN STANDARD TIME /8:30 A. M. to 5:00 P. M. PACIFIC STANDARD TIME

WEBSITE: [WWW.YOTRIOINT.COM](http://WWW.YOTRIOINT.COM)

TO ASSIST YOU BETTER, PLEASE GATHER THE FOLLOWING INFORMATION BEFORE CALLING CUSTOMER SERVICE:

PRODUCT NAME AND STYLE NUMBER, DESCRIPTION AND OR IMAGES OF THE ISSUE, ORIGINAL STORE

PURCHASE RECEIPT.