









## SAVE THESE INSTRUCTIONS

### SONOMA CLAREMONT C-SPRING CHAIR CHAT SET ASSEMBLY INSTRUCTIONS ASSEMBLE ON A FLAT, PROTECTED SURFACE.

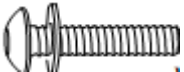
PART LIST	FIGURE	QUANTITY	DESCRIPTION
A		1 PC	RIGHT ARM
B		1 PC	LEFT ARM
C		1 PC	CHAIR FRAME
D		1 PC	REAR LEG CONNECTOR
E		8 PCS + 1 PC	FLAT WASHER + SHORT BOLT (M6*20MM)
F		2 PCS + 1 PC	FLAT WASHER + LONG BOLT (M6*30MM)
G		2 PCS + 1 PC	LEG LEVELER
H		1 PC	ALLEN WRENCH
I		1 PC	BACK CUSHION
J		1 PC	SEAT CUSHION

FOR MISSING OR INCORRECT PARTS/HARDWARE, CONTACT THE MANUFACTURER'S CUSTOMER SERVICE DIRECTLY AT  
1-866-905-4107 OR [WWW.YOTRIOINT.COM](http://WWW.YOTRIOINT.COM)  
REFER TO LAST PAGE FOR ADDITIONAL CUSTOMER SERVICE DETAILS.

**ASSEMBLY INSTRUCTIONS (CONTINUED)**  
**SONOMA CLAREMONT C-SPRING CHAIR CHAT SET ASSEMBLY INSTRUCTIONS**

**STEP 1**

A. PLACE CHAIR FRAME (C) ON A FLAT, PROTECTED SURFACE WHILE HOLDING IT ON ITS SIDE AS SHOWN.

B. CONNECT RIGHT ARM (A) TO SEAT OF CHAIR FRAME (C) WITH FLAT WASHERS AND SHORT BOLTS (E) USING ALLEN WRENCH (H). DO NOT TIGHTEN COMPLETELY.

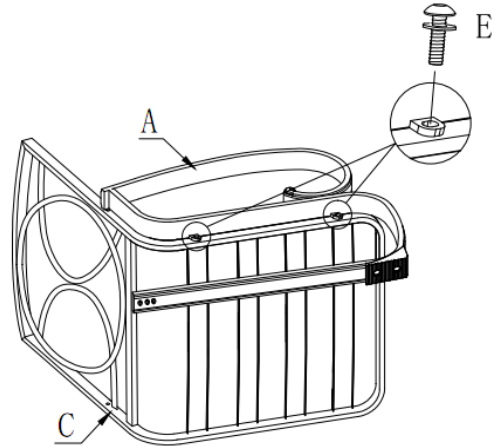

**STEP 2**

A. ROTATE ASSEMBLED UNIT TO HAVE RIGHT ARM ON FLAT, PROTECTED SURFACE.

B. CONNECT LEFT ARM (B) TO SEAT OF CHAIR FRAME (C) WITH FLAT WASHERS AND SHORT BOLTS (E) USING ALLEN WRENCH (H). DO NOT TIGHTEN COMPLETELY.

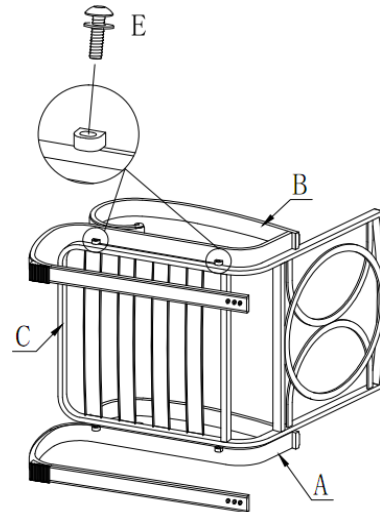

**STEP 3**

A. ROTATE ASSEMBLED UNIT TO THE STANDING POSITION.

B. CONNECT BACK OF CHAIR FRAME (C) TO RIGHT ARM (A) AND LEFT ARM (B) WITH FLAT WASHERS AND LONG BOLTS (F) USING ALLEN WRENCH (H). DO NOT TIGHTEN COMPLETELY.

C. COMPLETELY TIGHTEN ALL BOLTS WITH ALLEN WRENCH (H) FOR STEPS 1 THROUGH 3.

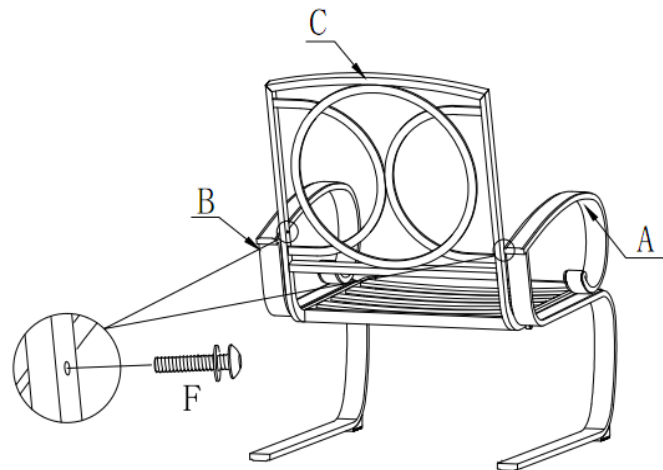

**ASSEMBLY INSTRUCTIONS (CONTINUED)**  
**SONOMA CLAREMONT C-SPRING CHAIR CHAT SET ASSEMBLY INSTRUCTIONS**

**STEP 4**

A. ROTATE ASSEMBLED CHAIR UPSIDE DOWN ON A FLAT, PROTECTED SURFACE.

B. CONNECT REAR LEG CONNECTOR (D) TO LEG OF RIGHT ARM (A) AND LEFT ARM (B) WITH FLAT WASHERS AND SHORT BOLTS (E) USING ALLEN WRENCH (H). TIGHTEN COMPLETELY.

C. INSERT LEG LEVELERS (G) INTO ENDS OF REAR LEG CONNECTOR (D).

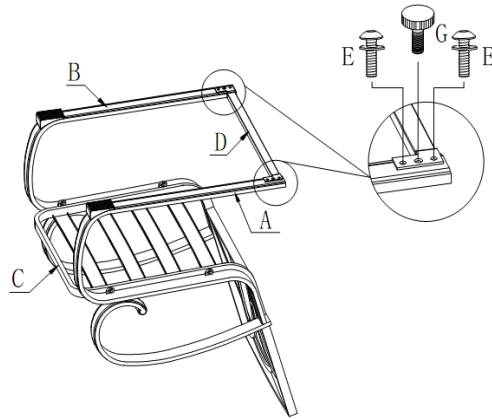

**STEP 5**

A. ROTATE CHAIR TO THE UPRIGHT POSITION.

B. PLACE SEAT CUSHION (J) ON CHAIR FRAME AND ATTACH WITH TIES TO BACK CROSSBAR THEN BACK CUSHION (I).

C. ADJUST LEG LEVELERS (G) SO THAT THE CHAIR SITS STABLE ON THE FLOOR.

D. ASSEMBLY IS COMPLETE.

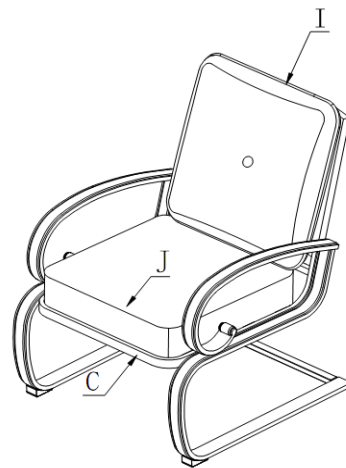

**\*\* WE RECOMMEND THAT YOU SAVE THE ALLEN WRENCH AND PERIODICALLY TIGHTEN ALL BOLTS.**

**WEIGHT LIMIT**

CHAIR: 250 LBS

**CARE AND CLEANING**

FRAME: WIPE CLEAN WITH A MILD SOAP AND WATER SOLUTION, RINSE WITH CLEAN WATER, AND DRY THOROUGHLY

CUSHION: SPOT CLEAN WITH A SOFT, DAMP CLOTH.

DO NOT STAND OR CLIMB ON CHAIR.

IN ORDER TO PROLONG THE LIFE OF YOUR CHAIR, PLEASE STORE IN DRY SHELTERED PLACE WHEN NOT IN USE OR DURING INCLEMENT WEATHER.

**WARRANTY**

1 YEAR LIMITED WARRANTY FOR FRAME AND CUSHIONS.

CUSTOMER SERVICE: PLEASE NOTE - DO NOT RETURN THIS ITEM TO THE RETAILER.

CUSTOMER SERVICE HOT LINE: 1-866-905-4107





SERVICE HOURS: 11:30 A. M. to 8:00 P. M. EASTERN STANDARD TIME /8:30 A. M. to 5:00 P. M. PACIFIC STANDARD T

WEBSITE: WWW.YOTRIJOINT.COM

TO ASSIST YOU BETTER, PLEASE GATHER THE FOLLOWING INFORMATION BEFORE CALLING CUSTOMER SERVICE:  
PRODUCT NAME AND STYLE NUMBER, DESCRIPTION AND OR IMAGES OF THE ISSUE, ORIGINAL STORE PURCHASE RECEIPT.

## SAVE THESE INSTRUCTIONS

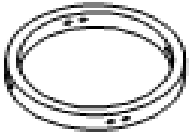
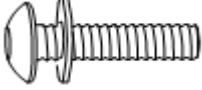
### SONOMA CLAREMONT SIDE TABLE CHAT SET ASSEMBLY INSTRUCTIONS ASSEMBLE ON A FLAT, PROTECTED SURFACE.

PART LIST	FIGURE	QUANTITY	DESCRIPTION
A		1 PC	TOP
B		4 PCS	LEG
C		1 PC	LEG CONNECTOR
D		12 PCS + 1 PC	FLAT WASHER + BOLT (M6*25MM)
E		1 PC	ALLEN WRENCH

FOR MISSING OR INCORRECT PARTS/HARDWARE, CONTACT THE MANUFACTURER'S CUSTOMER SERVICE DIRECTLY AT  
1-866-905-4107 OR [WWW.YOTRIOINT.COM](http://WWW.YOTRIOINT.COM)  
REFER TO LAST PAGE FOR ADDITIONAL CUSTOMER SERVICE DETAILS.

**ASSEMBLY INSTRUCTIONS (CONTINUED)**  
**SONOMA CLAREMONT SIDE TABLE CHAT SET ASSEMBLY INSTRUCTIONS**

**STEP 1**

A. PLACE TOP (A) UPSIDE DOWN ON A FLAT, PROTECTED SURFACE.

B. ATTACH LEGS (B) TO TOP (A) WITH FLAT WASHERS AND BOLTS (D) USING ALLEN WRENCH (E). DO NOT TIGHTEN COMPLETELY.

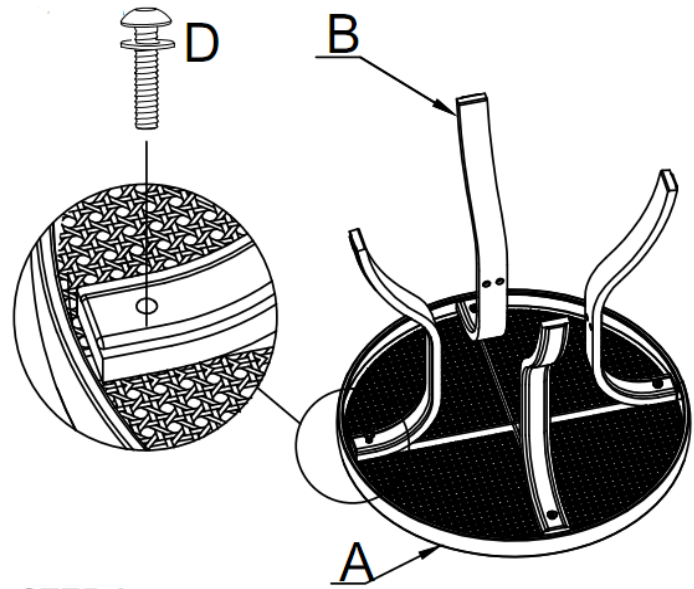

**STEP 2**

A. ATTACH LEG CONNECTOR (C) TO LEGS (B) WITH FLAT WASHERS AND BOLTS (D) USING ALLEN WRENCH (E). DO NOT TIGHTEN COMPLETELY.

B. TIGHTEN COMPLETELY ALL BOLTS ON LEG CONNECTOR (C) FIRST THEN AT TOP (A) WITH ALLEN WRENCH (E).

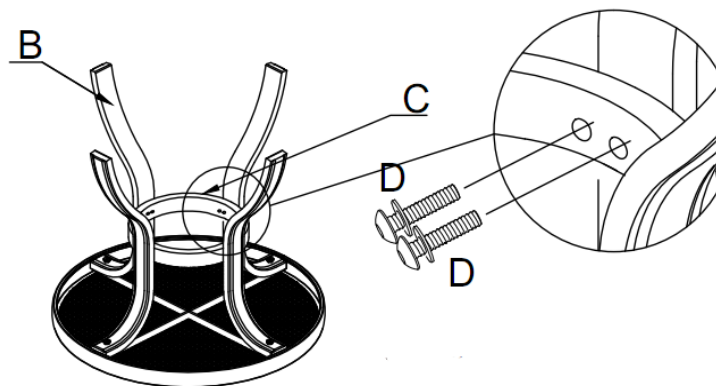

**ASSEMBLY INSTRUCTIONS (CONTINUED)**  
**SONOMA CLAREMONT SIDE TABLE CHAT SET ASSEMBLY INSTRUCTIONS**

**STEP 3**

A. ROTATE TABLE TO THE UPRIGHT POSITION.

B. ASSEMBLY IS COMPLETE.



**\*\* WE RECOMMEND THAT YOU SAVE THE ALLEN WRENCH AND PERIODICALLY TIGHTEN ALL BOLTS.**

**WEIGHT LIMIT**

SIDE TABLE: 115 LBS

**CARE AND CLEANING**

WIPE CLEAN WITH A MILD SOAP AND WATER SOLUTION, RINSE WITH CLEAN WATER, AND DRY THOROUGHLY.

DO NOT SIT, STAND, OR CLIMB ON TABLE.

IN ORDER TO PROLONG THE LIFE OF YOUR TABLE, PLEASE STORE IN DRY SHELTERED PLACE WHEN NOT IN USE OR DURING INCLEMENT WEATHER.

**WARRANTY**

1 YEAR LIMITED WARRANTY FOR FRAME AND CUSHIONS.

CUSTOMER SERVICE: PLEASE NOTE - DO NOT RETURN THIS ITEM TO THE RETAILER.

CUSTOMER SERVICE HOT LINE: 1-866-905-4107

SERVICE HOURS: 11:30 A. M. to 8:00 P. M. EASTERN STANDARD TIME /8:30 A. M. to 5:00 P. M. PACIFIC STANDARD T

WEBSITE: [WWW.YOTRIOINT.COM](http://WWW.YOTRIOINT.COM)

TO ASSIST YOU BETTER, PLEASE GATHER THE FOLLOWING INFORMATION BEFORE CALLING CUSTOMER SERVICE:  
PRODUCT NAME AND STYLE NUMBER, DESCRIPTION AND OR IMAGES OF THE ISSUE, ORIGINAL STORE PURCHASE RECEIPT.







