







SAVE THESE INSTRUCTIONS

RIDGE CREST FARMHOUSE FAUX WOOD A FRAME METAL DINING TABLE ASSEMBLY INSTRUCTIONS ASSEMBLE ON A FLAT, PROTECTED SURFACE.

PART LIST	FIGURE	QUANTITY	DESCRIPTION
A		1 PC	TABLE TOP
B		2 PC	TABLE LEG
C		1 PC	TABLE LEG SUPPORT TUBE
D		1 PC	UMBRELLA HOLE CAP
E	 M6*15	16+1 PCS	FLAT WASHER+BOLT(M6*15)
F		1 PC	ALLEN WRENCH

FOR MISSING OR INCORRECT PARTS/HARDWARE, CONTACT THE MANUFACTURER'S CUSTOMER SERVICE DIRECTLY AT
1-866-905-4107 OR WWW.YOTRIOINT.COM
REFER TO LAST PAGE FOR ADDITIONAL CUSTOMER SERVICE DETAILS.

RIDGE CREST FARMHOUSE FAUX WOOD A FRAME METAL DINING TABLE ASSEMBLY INSTRUCTIONS (CONT.)

STEP 1

A. PLACE TABLE TOP (A) UPSIDE DOWN ON A FLAT, PROTECTED SURFACE.

B. ATTACH TABLE LEGS (B) TO TABLE TOP (A) USING FLAT WASHER AND BOLT (E). LOOSELY TIGHTEN WITH ALLEN WRENCH (F).

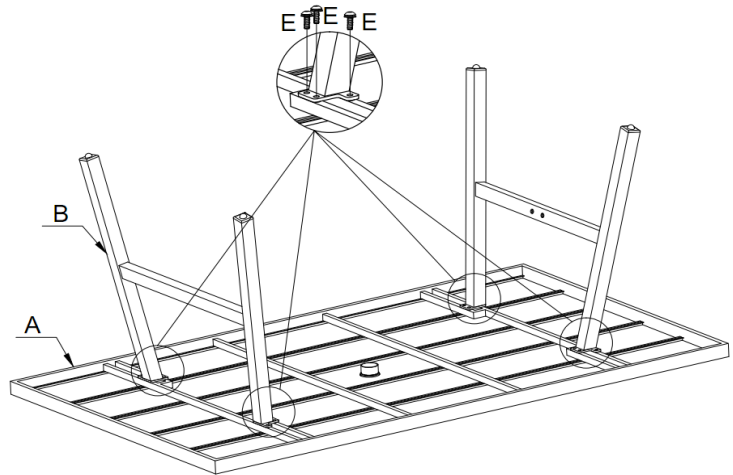

STEP 2

A. ATTACH TABLE LEG SUPPORT TUBE (C) TO TABLE LEG (B) USING FLAT WASHER AND BOLT (E).

B. AT THIS TIME, TIGHTEN ALL BOLTS COMPLETELY.

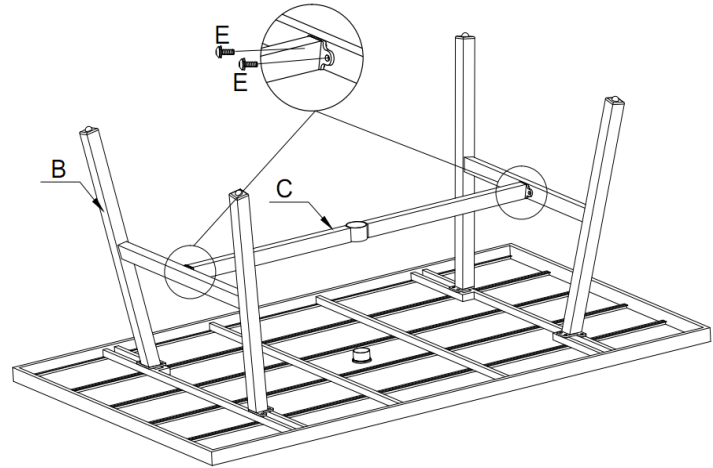

STEP 3

A. ROTATE TABLE TO UPRIGHT POSITION.

B. PLACE UMBRELLA HOLE CAP (D) ON TABLE TOP (A).

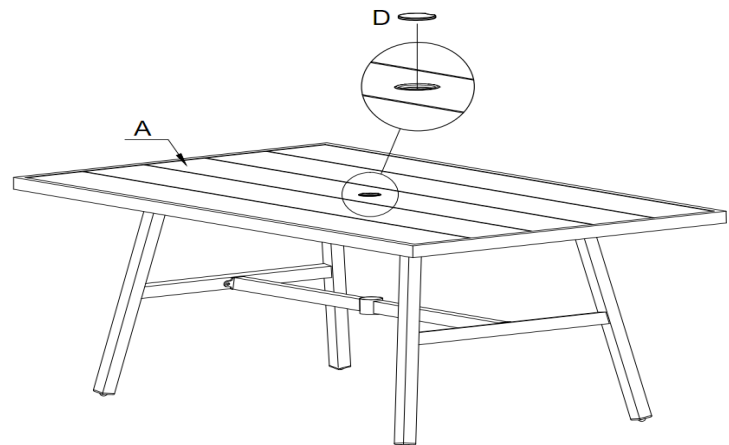

**RIDGE CREST FARMHOUSE FAUX WOOD A FRAME METAL DINING TABLE ASSEMBLY INSTRUCTIONS
(CONT.)**

STEP 4

A. ASSEMBLY IS COMPLETED. ADJUST LEVELERS ON TABLE LEGS (B) AS NEEDED.

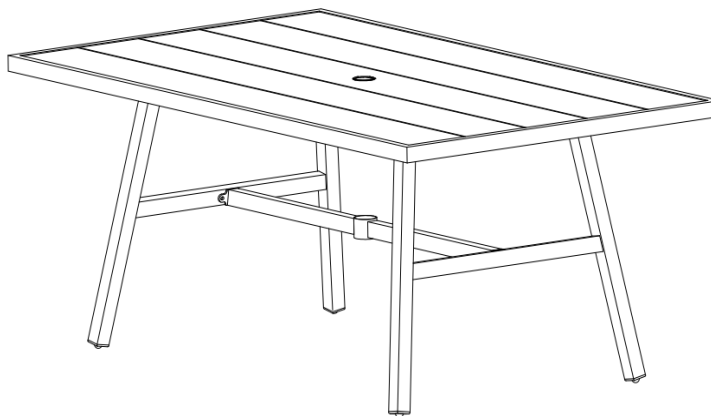

**** WE RECOMMEND THAT YOU SAVE THE ALLEN WRENCH (F) AND PERIODICALLY TIGHTEN ALL BOLTS.**

WEIGHT LIMIT

300 LBS

CARE AND CLEANING

IN ORDER TO PROLONG THE LIFE OF YOUR TABLE, PLEASE STORE IN DRY SHELTERED PLACE WHEN NOT IN USE OR DURING INCLEMENT WEATHER.

WARRANTY

1 YEAR LIMITED WARRANTY FOR FRAME.

CUSTOMER SERVICE: PLEASE NOTE - DO NOT RETURN THIS ITEM TO THE RETAILER.

CUSTOMER SERVICE HOT LINE: 1-866-905-4107

SERVICE HOURS: 11:30 A. M. to 8:00 P. M. EASTERN STANDARD TIME /8:30 A. M. to 5:00 P. M. PACIFIC STANDARD TIME

WEBSITE: WWW.YOTRIOINT.COM

TO ASSIST YOU BETTER, PLEASE GATHER THE FOLLOWING INFORMATION BEFORE CALLING CUSTOMER SERVICE: PRODUCT NAME AND STYLE NUMBER, DESCRIPTION AND OR IMAGES OF THE ISSUE, ORIGINAL STORE PURCHASE RECEIPT.