

Item # 1001 025 073, 1001 025 076
1001 025 074, 1001 025 075

Model # UTS00201E-RED, UTS00203E-GREY
UTS00203E-TAN, UTS00203E-BLACK

HAMPTON BAY[®]

USE AND CARE GUIDE

7.5 FT STEEL UMBRELLA



Questions, problems, missing parts? Before returning to the store,
call Hampton Bay Customer Service.
8 a.m. - 7 p.m., EST, Monday - Friday, 9 a.m. - 6 p.m., EST, Saturday

1-855-HD-HAMPTON

HOMEDEPOT.CA

THANK YOU

We appreciate the trust and confidence you have placed in Hampton Bay through the purchase of this umbrella. We strive to continually create quality products designed to enhance your home. Visit us online to see our full line of products available for your home improvement needs. Thank you for choosing Hampton Bay!

Table of Contents

Table of Contents.....	2	Planning Assembly	2
Warranty.....	2	Package Contents	3
What is Covered	2	Assembly	4
What is Not Covered	2	Operation	5
Pre-Assembly	2	Care and Cleaning	7

Warranty

1 YEAR FRAME AND FABRIC WARRANTY

WHAT IS COVERED

We warrant the frame and fabric to be free of manufacturing defects to the original purchaser for one year.

WHAT IS NOT COVERED

It remains the customer's responsibility for freight and packaging charges to and from our service center. This warranty does not cover commercial use, hardware, acts of nature, fire, freezing and abusive use. In addition, purchased parts are not covered under this warranty. We reserve the right to make substitutions with similar merchandise, if the model in question is no longer in production.

Contact the Customer Service Team at 1-855-HD-HAMPTON or visit www.Homedepot.ca.

Pre-Assembly

PLANNING ASSEMBLY

Read all instructions before assembly.

To avoid damaging this product, assemble it on a soft, non-abrasive surface such as carpet or cardboard.



NOTE: More than one person may be required to complete the assembly of this product.

Pre-Assembly (continued)

PACKAGE CONTENTS

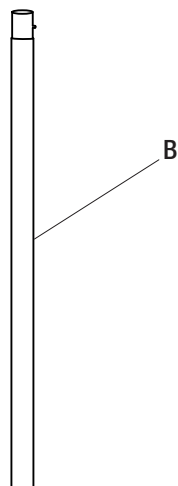
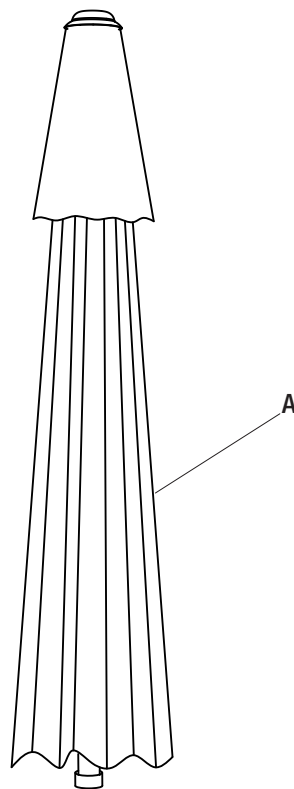

Part	Description	Quantity
A	Umbrella shade	1
B	Umbrella pole	1

Assembly

1 Connecting the umbrella shade to the umbrella pole

- Place the umbrella shade (A) over the umbrella pole (B).
- Hold down the tab on the umbrella pole (B) while you slide the umbrella shade (A) down into the umbrella pole (B) until the two pieces snap into place.

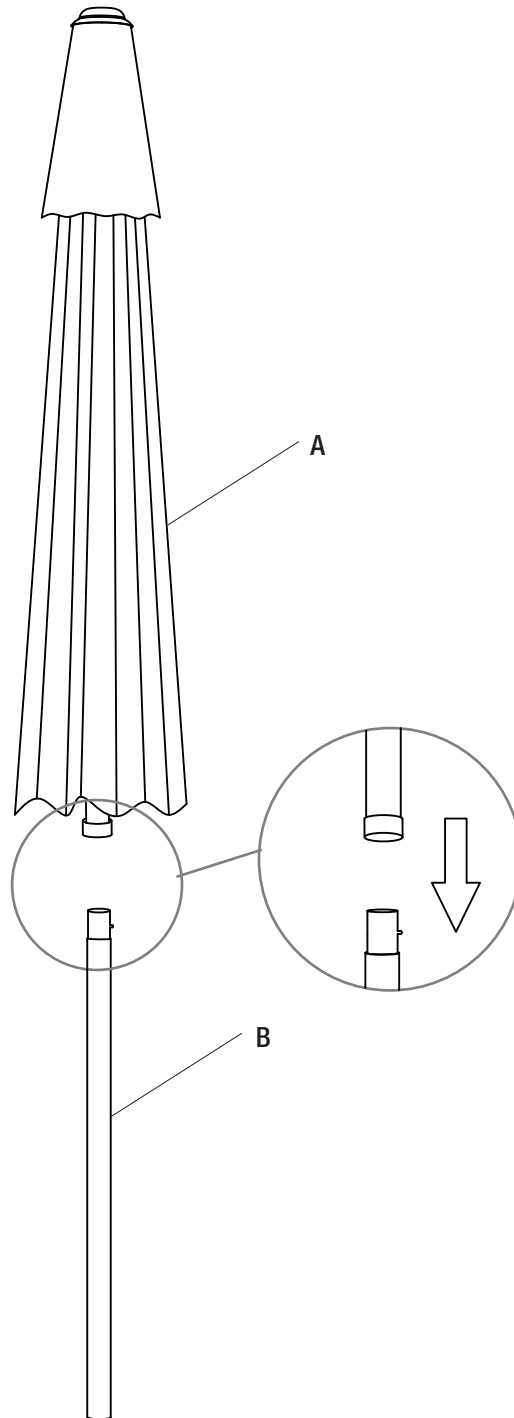

Operation

1 Opening the umbrella

- Shake the umbrella fabric before opening the umbrella.
- Push the button located on the umbrella shade (A) and move upwards.

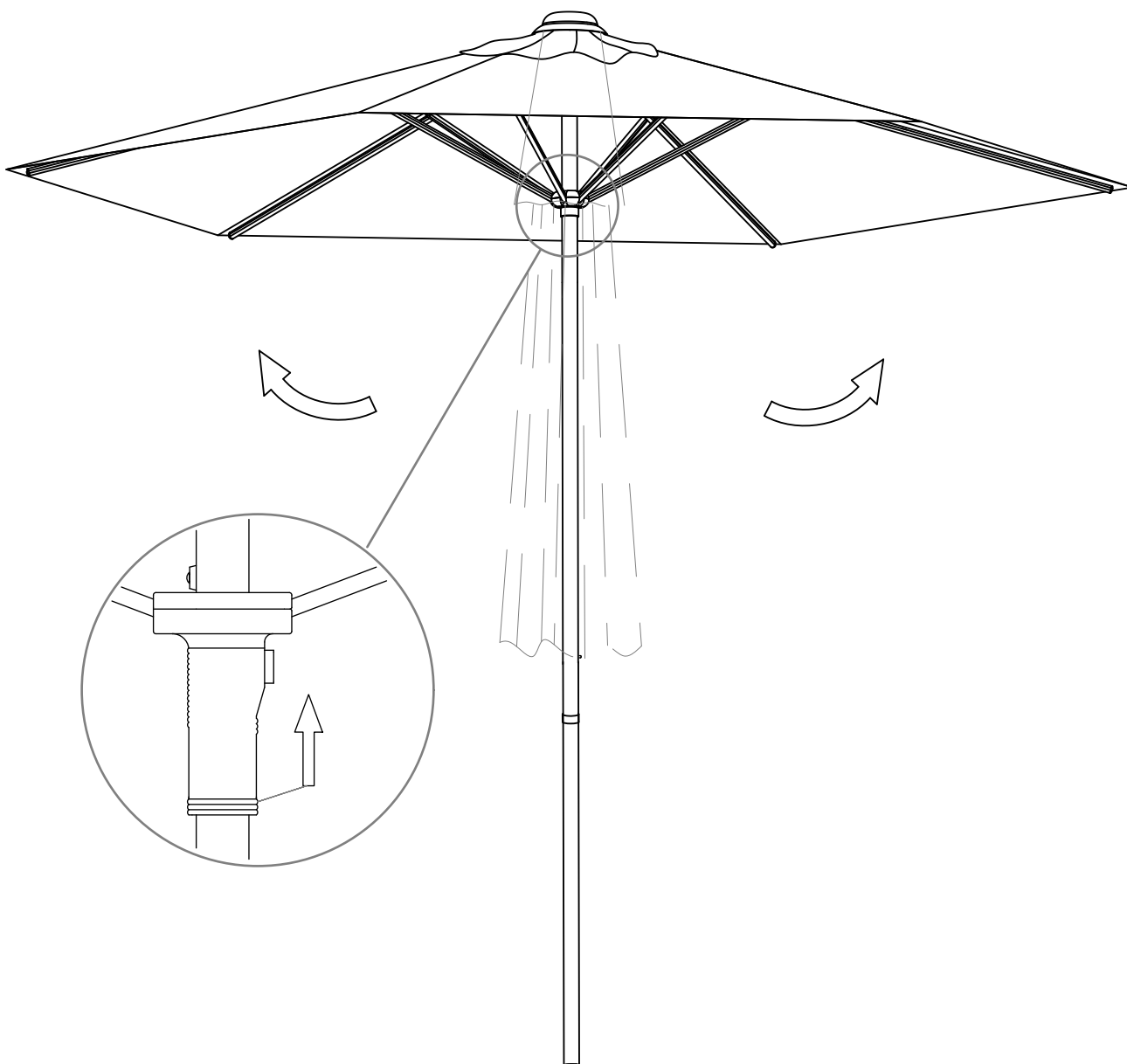

Operation (continued)

2 Closing the umbrella

- Push the button on the umbrella shade (A) and move downwards.

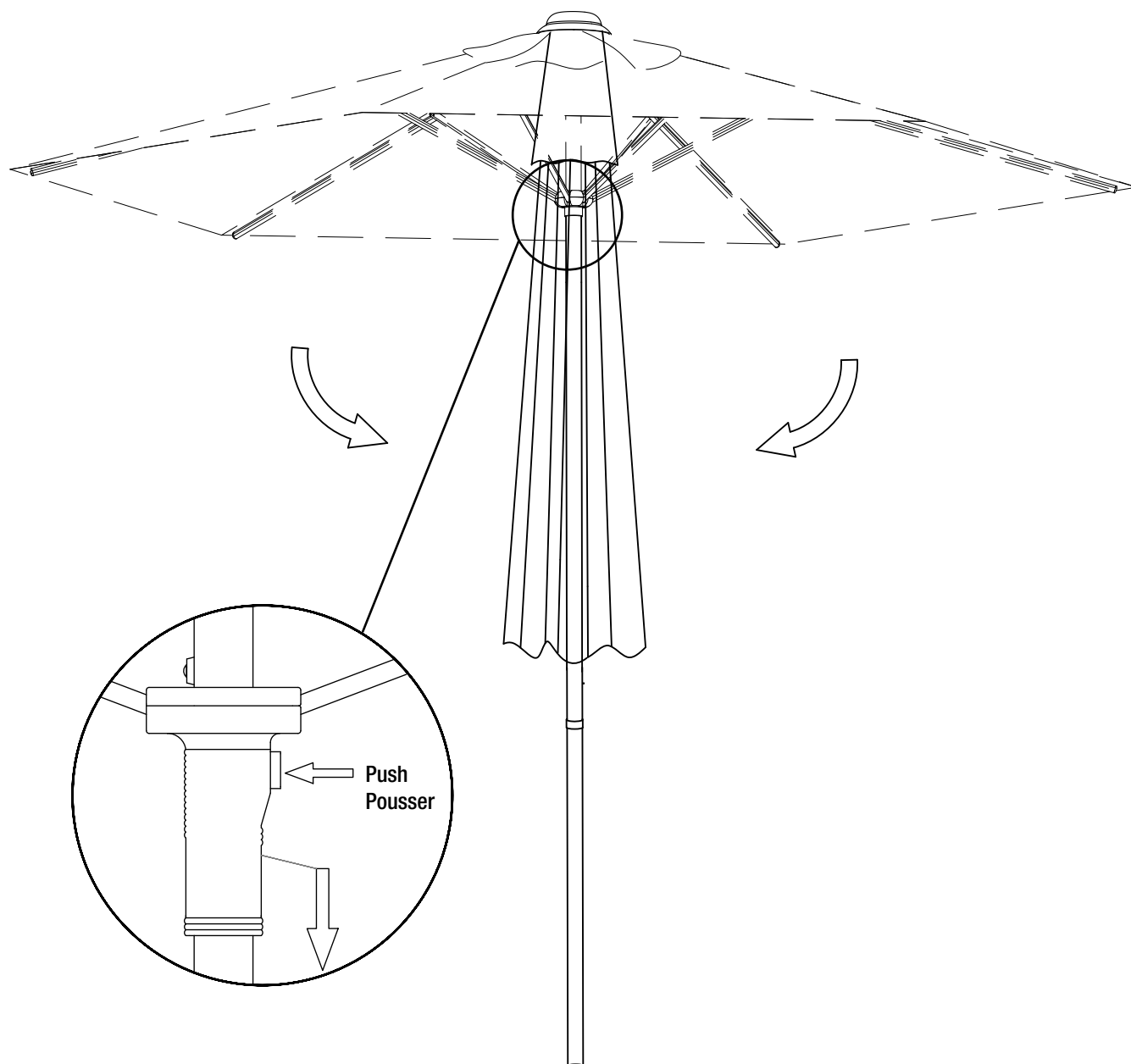

Operation (continued)

3 Storing the umbrella

- When not in use close the umbrella and store it.

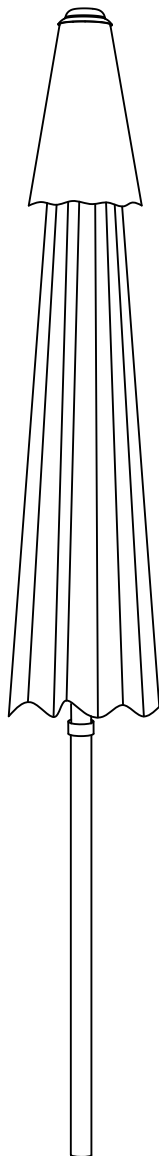

Care and Cleaning

- For best results, clean the frame and fabric with a damp cloth, and dry thoroughly. This will prevent mildew by removing dirt particles that may accumulate.
- Do not clean with abrasive materials, bleach or solvents.
- Store the umbrella in a dry, sheltered place when not in use.
- Keep the umbrella out of fire, extreme heat, freezing conditions, and inclement weather such as rain, hail, sleet, snow, or wind.

HAMPTON BAY[®]

Questions, problems, missing parts? Before returning to the store,
call Hampton Bay Customer Service.
8 a.m. - 7 p.m., EST, Monday - Friday, 9 a.m. - 6 p.m., EST, Saturday

1-855-HD-HAMPTON

HOMEDEPOT.CA

Retain this manual for future use.