

HAMPTON BAY

USE AND CARE GUIDE

SLAT 42 IN. SQUARE TABLE

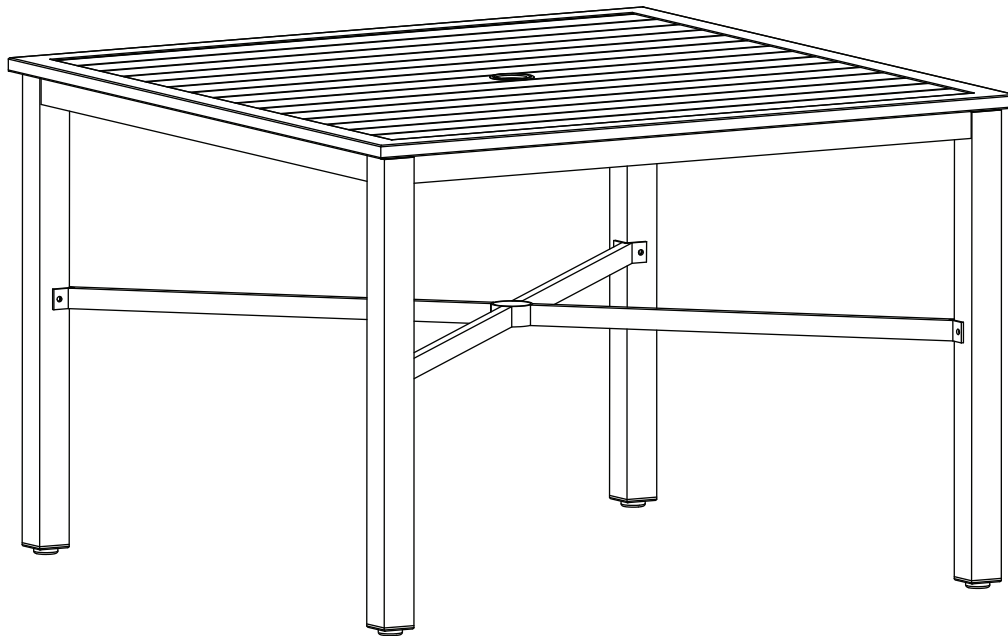

Questions, problems, missing parts? Before returning to the store,
call Hampton Bay Customer Service.
8 a.m. - 7 p.m., EST, Monday - Friday, 9 a.m. - 6 p.m., EST, Saturday

1-855-HD-HAMPTON

HOMEDEPOT.CA

THANK YOU

We appreciate the trust and confidence you have placed in Hampton Bay through the purchase of this table. We strive to continually create quality products designed to enhance your home. Visit us online to see our full line of products available for your home improvement needs. Thank you for choosing Hampton Bay!

Table of Contents

Table of Contents.....	2	Pre-Assembly	3
Important Safety Instructions	2	Planning Assembly	3
Save These Instructions	2	Hardware Included	3
Read All Instructions Before Use	2	Package Contents.....	4
Warranty	3	Assembly.....	5
What is Covered	3	Care and Cleaning.....	7
What is Not Covered	3		

Important Safety Instructions

SAVE THESE INSTRUCTIONS



WARNING: This table was as made for the explicit purpose of providing outdoor functions and is not to be used as a toy. This product is intended for normal outdoor use; however, the manufacturer recommends storing and / or covering this set when any formidable / severe weather is approaching.



WARNING: Do not locate this product near open flames. Do not use this product as a support. Do not shake, lean or climb on the product. Children under the age of 10, near the product, should be supervised by a competent adult at all times. This product is NOT intended for commercial use and will void the warranty.

READ ALL INSTRUCTIONS BEFORE USE

To reduce the risk of injury to persons:

1. Close supervision is necessary when this product is used by or near children, or disabled persons, if applicable.
2. Use this product only for its intended use as described in these instructions. Do not use attachments not recommended by the manufacturer.
3. Please keep children out of the assembly area before assembly.
4. This table is not intended to support an umbrella. Umbrellas must have a suitable base or stand.



WARNING: This table unit is heavy, and may require two adults for safe assembly.



WARNING: Never use this product as a support. Do not shake, lean, or climb on the product at any time.



CAUTION: When not in use, secure the product in a cool and covered location.



CAUTION: Do not place heavy objects on the table top.

Warranty

2 YEAR FRAME WARRANTY

WHAT IS COVERED

We warrant the frame to be free of manufacturing defects to the original purchaser for two years.

WHAT IS NOT COVERED

It remains the customer's responsibility for freight and packaging charges to and from our service center. This warranty does not cover commercial use, hardware, acts of nature, fire, freezing and abusive use. In addition, purchased parts are not covered under this warranty. We reserve the right to make substitutions with similar merchandise, if the model in question is no longer in production.

Contact the Customer Service Team at 01-800-00-46633 or visit www.Homedepot.ca.

Pre-Assembly

PLANNING ASSEMBLY

Read all instructions before assembly.

To avoid damaging this product, assemble it on a soft, non-abrasive surface such as carpet or cardboard.



NOTE: More than one person may be required to assemble this product.

HARDWARE INCLUDED



NOTE: Hardware not shown to actual size.

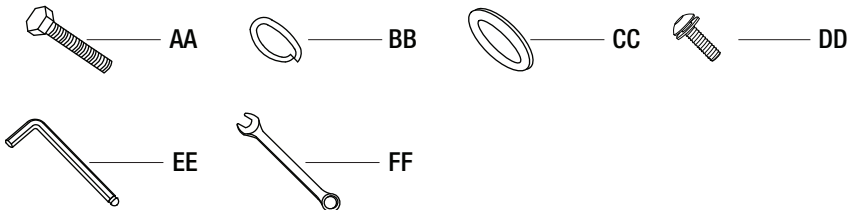

Part	Description	Quantity
AA	M8x50 bolt	4+1
BB	M8 spring washer	4+1
CC	M8 washer	4+1
DD	M6x15 combination bolt	8+1
EE	Hex wrench	1
FF	Wrench	1

Pre-Assembly (continued)

PACKAGE CONTENTS

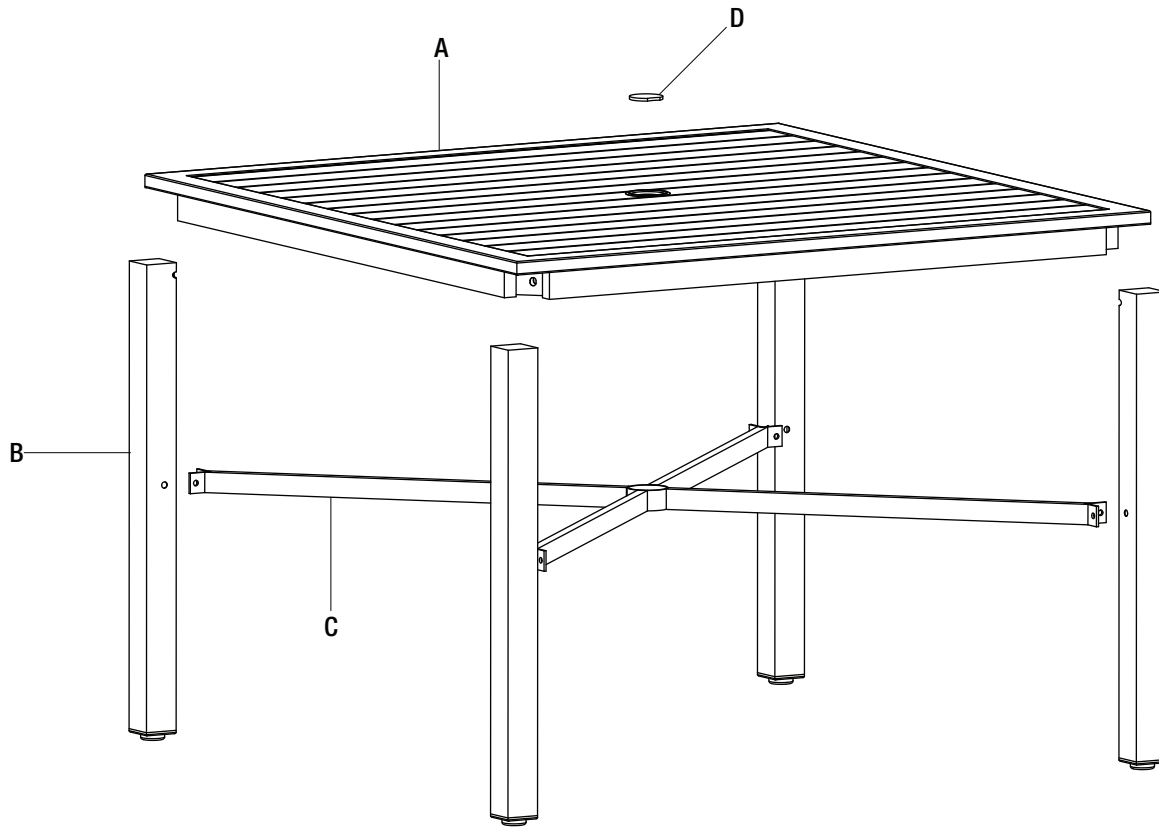

Part	Description	Quantity
A	Table top	1
B	Table leg	4
C	Leg connector	1
D	Umbrella ring cover	1

Assembly

1 Attaching the table legs to the table top

- Place the table top (A) upside down on a soft surface.
- Attach the table legs (B) to the table top (A) using M8x50 bolts (AA), M8 spring washers (BB) and M8 washers (CC).

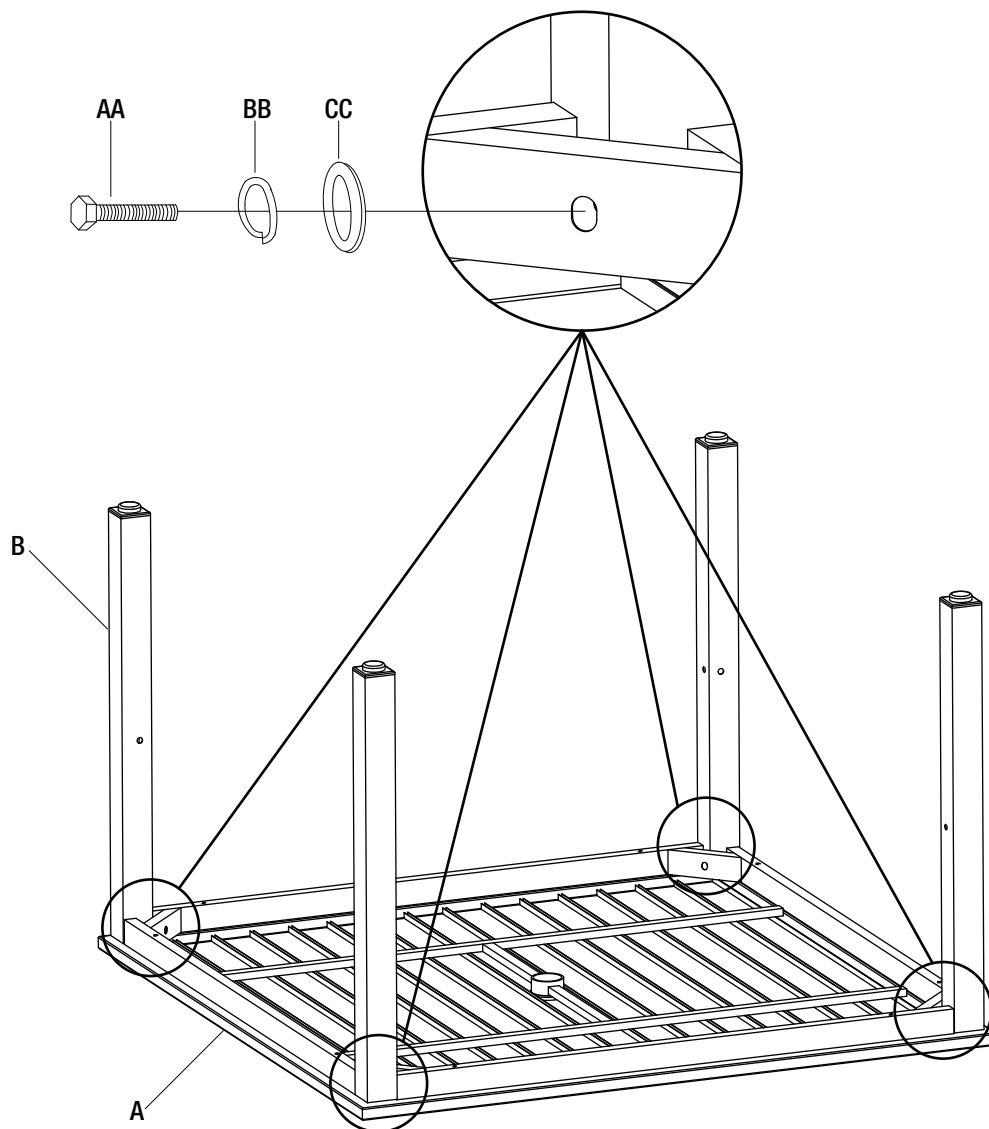

Assembly (continued)

2 Attaching the leg connector to the table legs

- Attach the leg connector (C) to the table legs (B) using M6x15 combination bolts (DD).

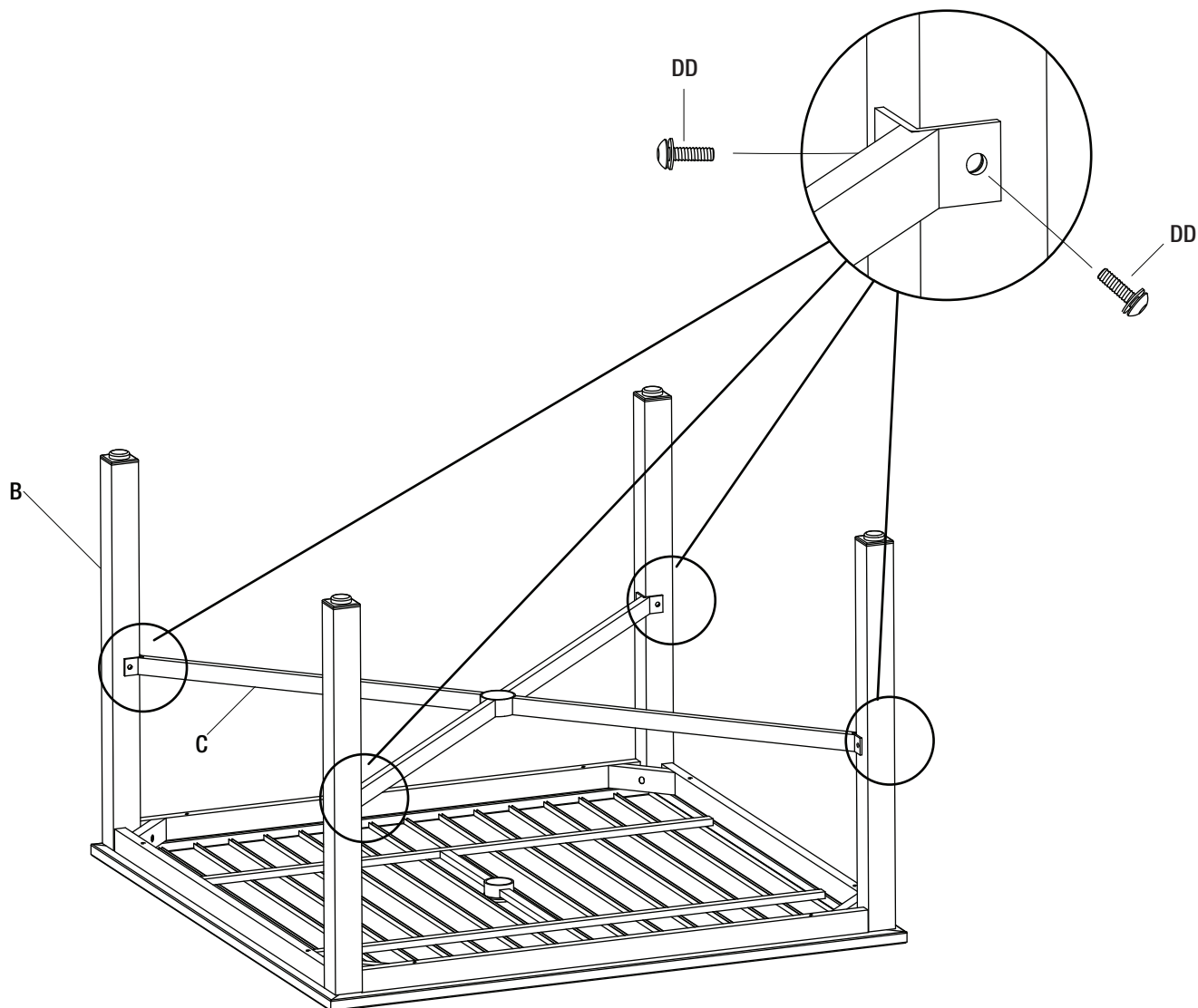

Assembly (continued)

3 Tightening the bolts

- Once all of the bolts are in place, fully tighten the bolts.
- Turn the table right side up.
- Put the umbrella ring cover (D) into the table top (A).
- Ensure the table is tightly assembled and stable before use.

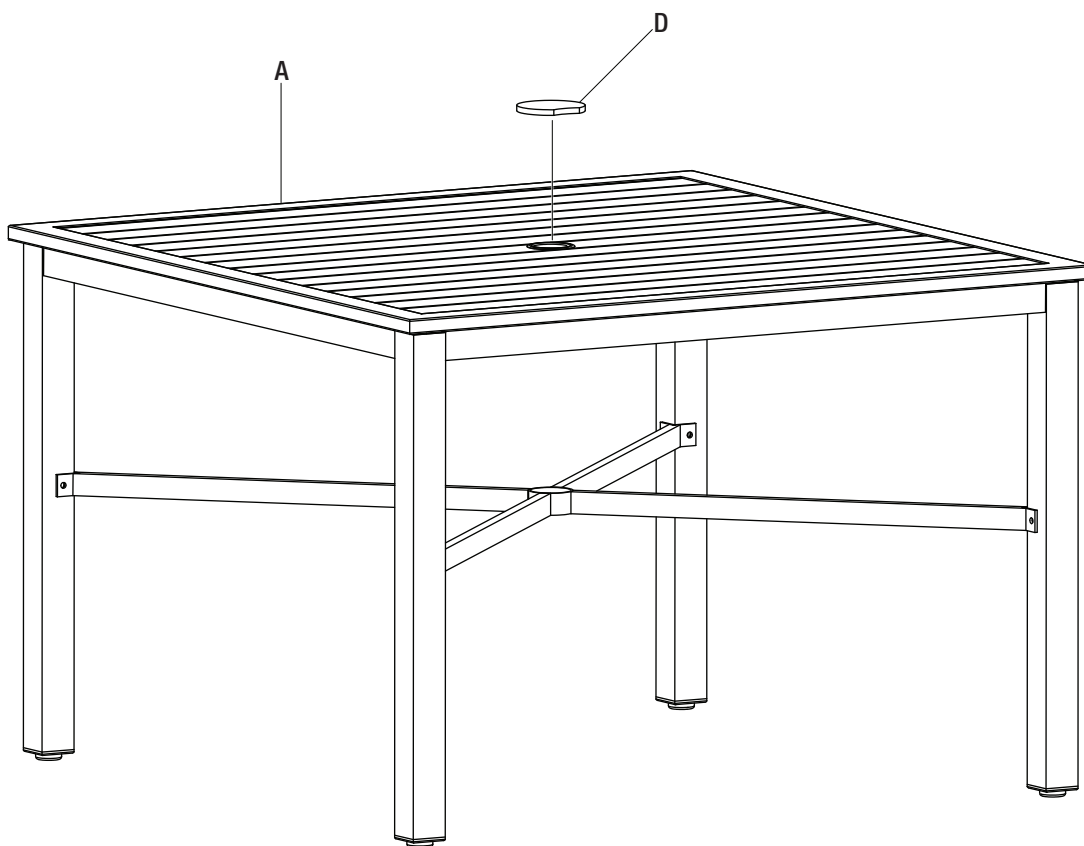

Care and Cleaning

- For best results, clean the table with a damp cloth and dry thoroughly. This will help prevent mildew by removing dirt particles that may accumulate.
- Do not clean with abrasive materials, bleach, or solvents.
- Store the table in a dry, sheltered place when not in use.
- Keep the table away from fire, extreme heat, freezing conditions, and inclement weather such as rain, hail, sleet, snow, or wind.

HAMPTON BAY®

Questions, problems, missing parts? Before returning to the store,
call Hampton Bay Customer Service.
8 a.m. - 7 p.m., EST, Monday - Friday, 9 a.m. - 6 p.m., EST, Saturday

1-855-HD-HAMPTON

HOMEDEPOT.CA

Retain this manual for future use.

For certification use only
Factory ID # FTS70660