

DO NOT RETURN TO RETAILER

IF YOU HAVE ANY QUESTIONS OR CONCERNS
PLEASE VISIT OUR WEBSITE AT:

www.yotrioint.com

OR TOLL FREE AT:

1-866-905-4107

MONDAY-FRIDAY 8:30 AM TO 5:00 PM PACIFIC TIME /
11:30 AM TO 8:00 PM EASTERN TIME

Warranty

1 YEAR FRAME AND 1 YEAR FABRIC LIMITED WARRANTY

WHAT IS COVERED

We warrant the frames to be free of manufacturing defects to the original purchaser for one year, and a one year limited warranty for the fabric.

WHAT IS NOT COVERED







It remains the customer's responsibility for freight and packaging charges to and from our service center. This warranty does not cover commercial use, hardware, acts of nature, fire, freezing and abusive use. In addition, purchased parts are not covered under this warranty. We reserve the right to make substitutions with similar merchandise, if the model in question is no longer in production.

⚠ WARNING

For your own safety, and to reduce the risk of serious personal injury, the user must read and understand this Use and Care Guide, and assemble each piece only in accordance with these instructions and with the parts and hardware included with the original packaging.

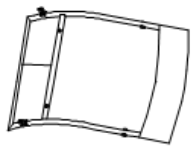
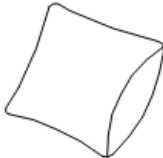
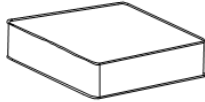
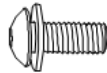
Failure to follow instructions and/or use of tools or hardware not included in the original packaging may lead to improper assembly and/or risk of serious personal injury.

PARTS LIST

PART	QTY	PICTURE	DESCRIPTION
A	1 PC		LEFT ARM
B	1 PC		RIGHT ARM
C	1 PC		SEAT PANEL
D	1 PC		BACK PANEL
E	1 PC		BACK CUSHION
F	1PC		SEAT CUSHION
G	6PCS		BOLT (M6*15)
H	4PCS		BOLT(M6*45)
I	10 PCS		WASHER
J	1 PC		ALLEN WRENCH

Assembly:

STEP 1

- A. PLACE LEFT ARM (A) ON A SOFT, PROTECTED SURFACE.
- B. ATTACH SEAT PANEL (C) TO THE LEFT ARM (A) BY USING BOLT (M6*15) (G) AND WASHER (I).
- C. COMPLETELY TIGHTEN ALL BOLTS WITH ALLEN WRENCH (J).

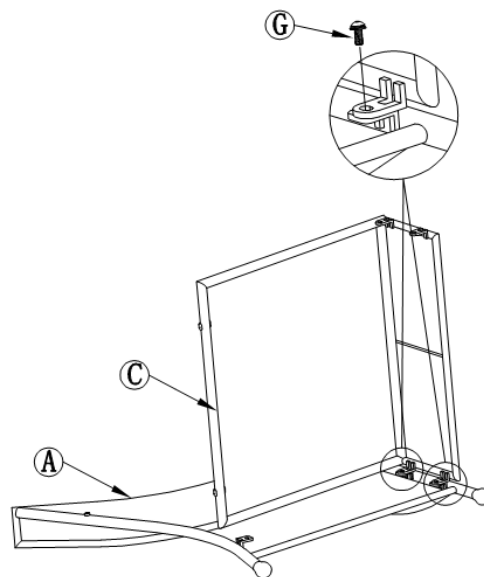

STEP 2

- D. ATTACH BACK PANEL (D) AND SEAT PANEL (C) BY USING BOLT (M6*45) (H), WASHER (I) AND ALLEN WRENCH (J).
- E. ATTACH BACK PANEL (D) AND LEFT ARM (A) BY USING BOLT (M6*15) (G), WASHER (I) AND ALLEN WRENCH (J).
- F. COMPLETELY TIGHTEN ALL BOLTS WITH ALLEN WRENCH (J).

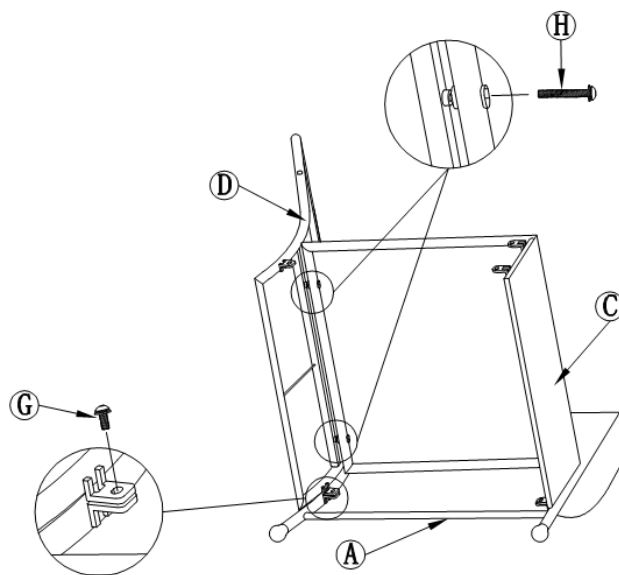

STEP 3

- G. ATTACH BACK PANEL (D), SEAT PANEL (C) AND RIGHT ARM (B) BY USING BOLT (M6*15) (G), WASHER (I) AND ALLEN WRENCH (J).
- H. COMPLETELY TIGHTEN ALL BOLTS WITH ALLEN WRENCH (J).

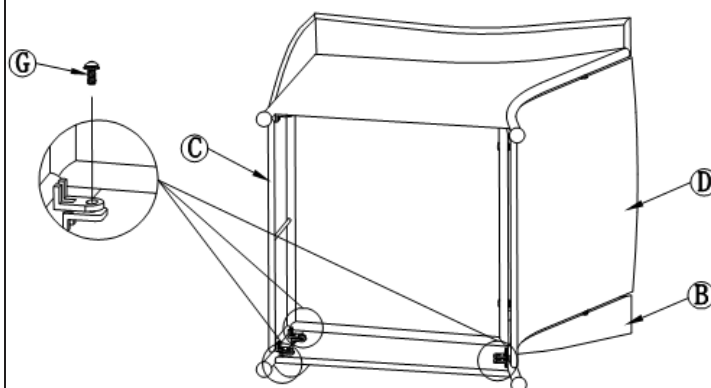

Assembly:

STEP 4.

- I. ATTACH BACK PANEL (D) TO THE LEFT ARM (A) AND RIGHT ARM(B) BY USING BOLT (M6*45) (H) , WASHER(I) AND ALLEN WRENCH (J)
- J. COMPLETELY TIGHTEN ALL BOLTS WITH ALLEN WRENCH (J).

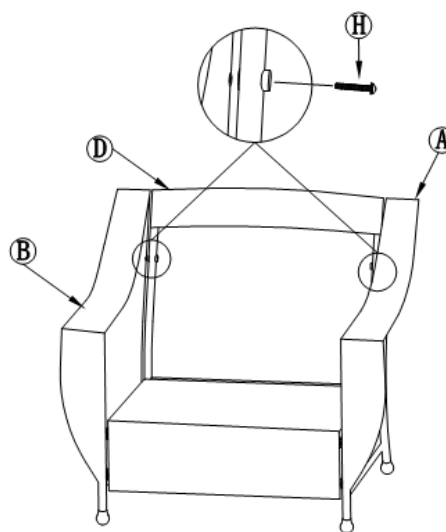

STEP 5.

- K. PLACE SEAT CUSHION (F) AND BACK CUSHION (E) ON CHAIR.
- L. ENSURE ALL CONNECTIONS ARE SECURE BEFORE USE.
- M. PERIODICALLY TIGHTEN ALL BOLTS THAT MAY HAVE BECOME LOOSE USING ALLEN WRENCH (J).

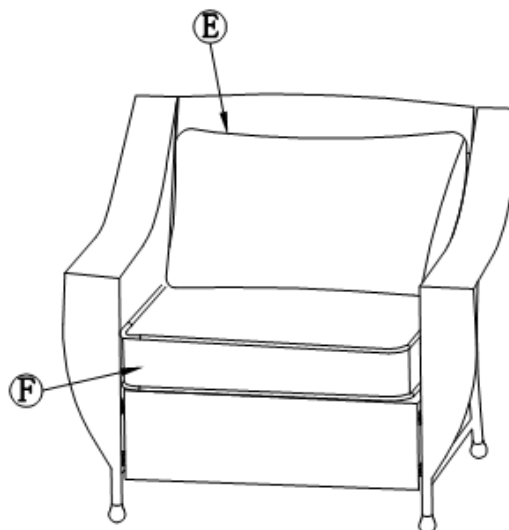

WARNING

THE WEIGHT LIMIT FOR THIS CHAIR IS 250 LBS (112.5 KG). ANY USE BY AN INDIVIDUAL WEIGHING MORE THAN 250 LBS (112.5 KG) MAY LEAD TO CHAIR IMBALANCE AND/OR TIPPING, AND RISK OF SERIOUS PERSONAL INJURY.

CARE AND CLEANING

FRAME: WIPE CLEAN WITH A MILD SOAP AND WATER SOLUTION, RINSE WITH CLEAN WATER, AND DRY THOROUGHLY.

IN ORDER TO PROLONG THE LIFE OF YOUR CHAIR, PLEASE STORE IN DRY SHELTERED PLACE WHEN NOT IN USE OR DURING INCLEMENT WEATHER.

