



DO NOT RETURN TO RETAILER

IF YOU HAVE ANY QUESTIONS OR CONCERNS
PLEASE VISIT OUR WEBSITE AT:

www.yotrioint.com

OR TOLL FREE AT:

1-866-905-4107

MONDAY-FRIDAY 8:30 AM TO 5:00 PM PACIFIC STANDARD TIME / 11:30
AM TO 8:00PM EASTERN STANDARD TIME

YOTRIO CUSTOMER CARE

Warranty Coverage Requirements:

1. Copy of your Original Store Receipt.
2. Pictures of the damaged parts.
3. You must know the name of your product and any corresponding item numbers as well as the name of the store where you purchased the item.
4. Please gather all of this information BEFORE you call customer service.



NE PAS RETOURNER AU DÉTAILLANT

SI VOUS AVEZ DES QUESTIONS OU DES PRÉOCCUPATIONS,
VEUILLEZ VISITER NOTRE SITE WEB À L'ADRESSE :

www.yotrio.com

OU APPELER SANS FRAIS AU :

1-866-905-4107

DU LUNDI AU VENDREDI, DU 8 H 30 À 17 H, HEURE NORMALE DU
PACIFIQUE / 11 H 30 À 20 H HEURE NORMALE DE L'EST

SERVICE À LA CLIENTÈLE YOTRIO

Conditions d'admissibilité de la garantie :

1. Copie de votre reçu de caisse original.
2. Photos des pièces endommagées.
3. Vous devez connaître le nom de votre produit et tout numéro d'article correspondant, ainsi que le nom du magasin où vous avez acheté l'article.
4. Veuillez recueillir tous ces renseignements AVANT de communiquer avec le service à la clientèle.

CARE AND MAINTENANCE

- ❖ Before using, wipe the product completely with a soft, dry cloth.
- ❖ Spot-clean Cushions and slings using a sponge, mild soap and water. Rinse thoroughly with clean water. To prevent mildew, allow to air dry completely before using or storing.
- ❖ Never machine wash or tumble dry cushions, slings or umbrella covers as this will result in shrinkage or damage.
- ❖ Rinse wicker patio furniture with a hose or pressure washer. If the wicker is really dirty, you can use mild soap with water. Allow to dry completely before using or storing.
- ❖ To clean your patio umbrella, use a soft brush and mild soap and water. Allow to dry completely before storing.
- ❖ Avoid placing hot objects directly onto table top surface without a heat protector.
- ❖ Always store and/or cover your patio furniture in a cool dry place when not in used and away from direct sunlight.
- ❖ When storing, never wrap cushions in plastic. Plastic doesn't allow the cushion to breathe and can cause it to mildew if there's any moisture present.
- ❖ Always place your patio furniture away from fire, extreme heat, freezing conditions and inclement weather such as rain, hail, sleet, snow or wind.
- ❖ Never use bleach or strong solvents to clean as this will cause damage to both fabric and metal finishes.
- ❖ Do not allow water to build up in frames as this will cause corrosion and damage.

ONE-YEAR FRAME AND ONE-YEAR FABRIC/WICKER/FINISH ETC. LIMITED WARRANTY

You must retain the original receipt to obtain warranty service.

- ❖ Frames are warranted against defects in materials and workmanship for a period of one year from the date of original purchase.
This warranty does not cover damage to frames or welds due to commercial use, improper assembly, acts of nature, fire, freezing and abusive use.
- ❖ Rust, corrosion, and/ or rust stains are not covered by warranty.
- ❖ Purchased parts are not covered under this warranty.
- ❖ Fabric on cushions, slings and umbrella is warranted one year against separation at the seams.
Fading, mildew, and color discoloration due to exposure to the elements, chemicals and spills are not covered.
- ❖ The Powder coat and/ or paint are warranted one year against blistering, peeling, or crackling.
Fading due to exposure to elements, chemicals and spills is not covered. Scratches and chips due to normal wear and use are not covered.
- ❖ Wicker Weave are warranted one year against breakage, separation, or tearing.
Fading or discoloration due to exposure from chemicals, spills and/ or the elements is not covered.
- ❖ Warranty covers free replacement of item within one year of purchase. After the one year it remains the customer's responsibility for freight and packaging charges to and from our service center.
- ❖ We do not compensate the individual or any outside party for assembling or disassembling the product.
- ❖ Any replacement of warranted items will be in the original style and color, or similar style and color if the original is un-available or has been discontinued.
Questions, problems, missing parts? Before returning to your retailer, call our customer service department at (866) 905-4107, 8:30 a.m. – 5:00 p.m. PST /11:30 a.m.- 8:00 p.m., EST, Monday- Friday.

SOIN ET ENTRETIEN

- ❖ Avant l'utilisation, essuyez le produit entièrement avec une serviette douce et sèche.
- ❖ Enlevez les-taches des coussins et toiles avec une éponge, un savon doux et de l'eau. Rincez complètement à l'eau propre. Pour éviter la moisissure, laissez complètement sécher à l'air avant d'utiliser ou de ranger.
- ❖ Ne lavez jamais les coussins, les éléments en toile ou toiles de parasol à la machine et ne les séchez jamais dans une sècheuse, car ils pourraient rétrécir ou être endommagés.
- ❖ Rincez le mobilier de jardin en osier avec un tuyau d'arrosage ou laveuse à haute pression. Si l'osier est vraiment sale, vous pouvez utiliser un savon doux et de l'eau. Laissez complètement sécher à l'air avant d'utiliser ou de ranger.
- ❖ Pour nettoyer votre parasol de jardin, utilisez une brosse douce et un savon doux et de l'eau. Laissez sécher complètement avant de ranger.
- ❖ Évitez de placer des objets très chauds sur la surface du plateau de table sans protection.
- ❖ Rangez et/ou recouvrez toujours votre mobilier de jardin dans un emplacement frais et sec lorsqu'il n'est pas utilisé et éloigné de la lumière directe du soleil.
- ❖ Lorsque vous rangez le mobilier, n'enveloppez jamais les coussins dans du plastique. Le plastique ne permet pas aux coussins de respirer et peut causer la moisissure si une humidité quelconque est présente.
- ❖ Placez toujours votre mobilier de jardin éloigné du feu, de la chaleur extrême, des conditions de gel et des intempéries telles que pluie, grêle, grésil, neige ou vent.
- ❖ N'utilisez jamais d'eau de Javel ou de solvants puissants pour nettoyer puisque ceci pourrait endommager le tissu et les finis métalliques.
- ❖ Ne laissez pas d'eau s'accumuler dans les armatures, puisque ceci pourrait causer la corrosion et endommager le produit.

GARANTIE D'UN AN SUR L'ARMATURE ET GARANTIE LIMITÉE D'UN AN SUR LE TISSU/OSIER/FINI ETC.

Vous devez conserver votre reçu initial pour vous prévaloir de la garantie.

- ❖ Les armatures sont garanties contre les défauts de fabrication et de matériaux pour une période d'un an à compter de la date d'achat initiale.
Cette garantie ne couvre pas les dommages aux armatures ou soudures découlant d'un usage commercial, d'un mauvais assemble, de catastrophes naturelles, d'un incendie, du gel et d'un usage abusif.
- ❖ La rouille et la corrosion ne sont pas couvertes par la garantie.
- ❖ Les pièces de rechange achetées ne sont pas couvertes par la présente garantie.
- ❖ Le tissu des coussins, toiles et parasols est garanti contre la déchirure des coutures pour une période d'un an.
- ❖ La décoloration, la moisissure et l'altération des couleurs résultant d'une exposition aux intempéries, à des produits chimiques et à des déversement ne sont pas couvertes.
- ❖ Le revêtement en poudre et/ou la peinture sont garantis contre les boursoflures, le décollement ou les craquelures pour une période d'un an.
- ❖ La décoloration résultant de l'exposition aux intempéries, aux produits chimiques ou aux produits de nettoyage abrasifs, n'est pas couverte. Les éraflures et l'écaillage causés par une usure normale ne sont pas couverts.
- ❖ Le tressage et les courroies sont garantis contre les bris, fissures ou déchirures pour une période d'un an.
- ❖ La décoloration ou l'altération des couleurs causée par une exposition aux produits chimiques, à des déversements et/ou aux intempéries n'est pas couverte.
- ❖ La garantie couvre un remplacement gratuit de l'article dans l'année suivant la date d'achat. Au bout d'un an, le client doit payer les frais d'emballage et de transport aller-retour au centre de service.
- ❖ Nous n'offrons pas de rémunération pour l'assemblage ou le démontage du produit par un particulier ou un tiers.
- ❖ Tout produit remplacé ou couvert par la garantie le sera dans son modèle et sa couleur d'origine, ou dans un modèle ou une couleur similaire si le produit original n'est pas dis-ponible ou a été abandonné.
Questions, problèmes, pièces manquantes? Avant de retourner à votre détaillant, veuillez appeler notre service à la clientèle au (866) 905-4107 entre 8h30 et 17h00, HNP ou 11h30 - 20h00, HNE, du lundi- au vendredi.

Walmart Assembly Instruction

TUSCANY 2PERSON PATIO SWING

Vendor stock No.: GCS00283D

NOTE: The M8 Bolt Cover (LL), M6 Bolt Cover (MM), M8 PLASTIC Cap (NN), M6 PLASTIC Cap (OO) in step 1 to 8 are only for reference. Please attach them to bolts in step 9.

Package Contents

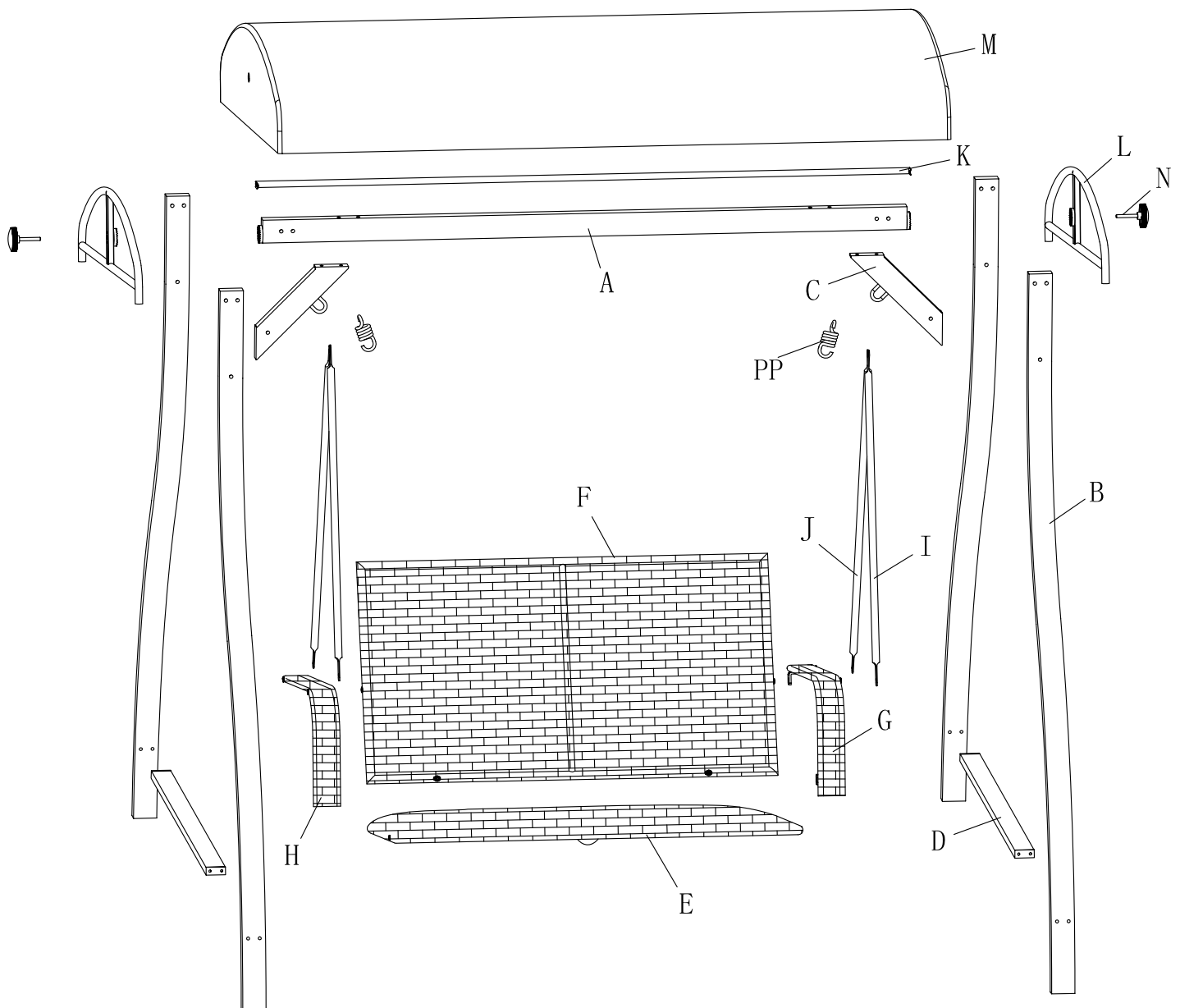

Questions, problems, missing parts? Before returning to your retailer, call our customer service department at (866) 905 - 4107, 8:30 a.m. - 5:00 p.m. PST/11:30 a.m. - 8:00 p.m., EST, Monday - Friday.











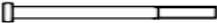







Walmart Assembly Instruction

TUSCANY 2PERSON PATIO SWING

Vendor stock No.: GCS00283D

NOTE: The M8 Bolt Cover (LL), M6 Bolt Cover (MM), M8 PLASTIC Cap (NN), M6 PLASTIC Cap (OO) in step 1 to 8 are only for reference. Please attach them to bolts in step 9.

Hardware Contents

PART NO.	PICTURE	DESCPRITION	QTY
AA		M8x105 Bolt	6
BB		M8x70 Bolt	4
CC		M8x20 Bolt	2
DD		M6x50 Bolt	2
EE		M6x40 Bolt	8
FF		M6x30 Bolt	2
GG		M6x20 Bolt	6
HH		M8 Nut	6
II		M6 Nut	2
JJ		M8 Washer	18
KK		M6 Washer	18
LL		M8 Bolt Cover	6
MM		M6 Bolt Cover	2
NN		M8 Plastic Cap	12
OO		M6 Plastic Cap	16
PP		Hook	2
QQ		Allen Wrench	1
RR		Wrench	1











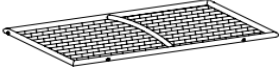
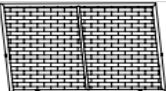

Questions, problems, missing parts? Before returning to your retailer, call our customer service department at (866) 905 - 4107, 8:30 a.m. - 5:00 p.m. PST/11:30 a.m. - 8:00 p.m., EST, Monday - Friday.

Walmart Assembly Instruction

TUSCANY 2PERSON PATIO SWING

Vendor stock No.: GCS00283D

NOTE: The M8 Bolt Cover (LL), M6 Bolt Cover (MM), M8 PLASTIC Cap (NN), M6 PLASTIC Cap (OO) in step 1 to 8 are only for reference. Please attach them to bolts in step 9.

PART NO.	PICTURE	DESCPRITION	QTY
A		Top Bar	1
B		Leg	4
C		Short Connector	2
D		Leg Connector	2
E		Seat	1
F		Back	1
G		Right Arm	1
H		Left Arm	1
I		Short Hanging Bar	2
J		Long Hanging Bar	2
K		Top Straight Bar	1
L		Top Curved Bar	2
M		Canopy	1
N		Knob	2

Questions, problems, missing parts? Before returning to your retailer, call our customer service department at (866) 905 - 4107, 8:30 a.m. - 5:00 p.m. PST/11:30 a.m. - 8:00 p.m., EST, Monday - Friday.

Walmart Assembly Instruction

TUSCANY 2PERSON PATIO SWING

Vendor stock No.: GCS00283D

NOTE: The M8 Bolt Cover (LL), M6 Bolt Cover (MM), M8 PLASTIC Cap (NN), M6 PLASTIC Cap (OO) in step 1 to 8 are only for reference. Please attach them to bolts in step 9.

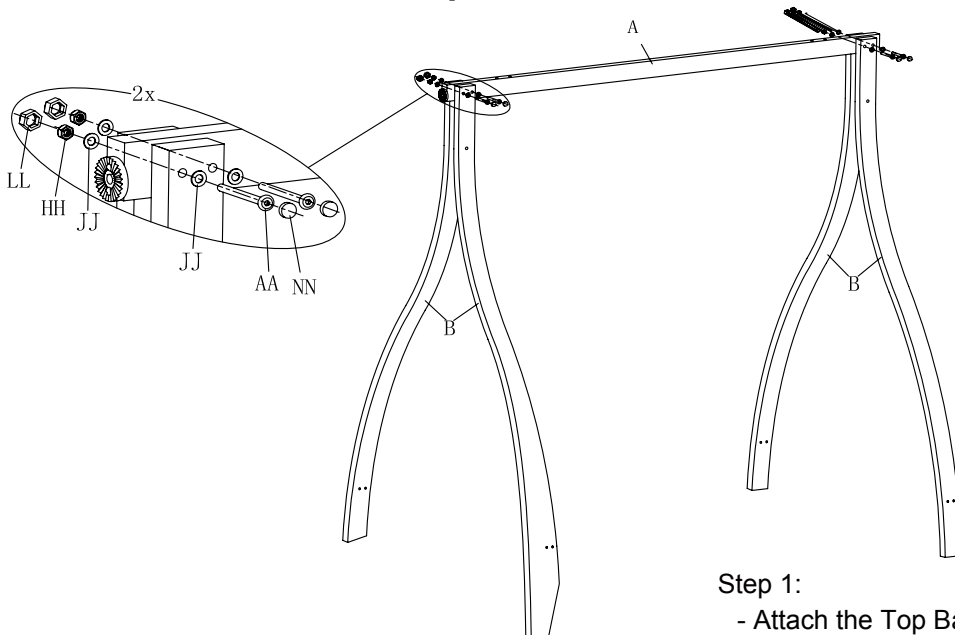

Step 1:

- Attach the Top Bar (A) to the Leg (B).
- Connect with M8 x 105 Bolt (AA), the M8 Washer (JJ) and the M8 Nut (HH) as shown in the picture.
- Loosely tighten by hand.

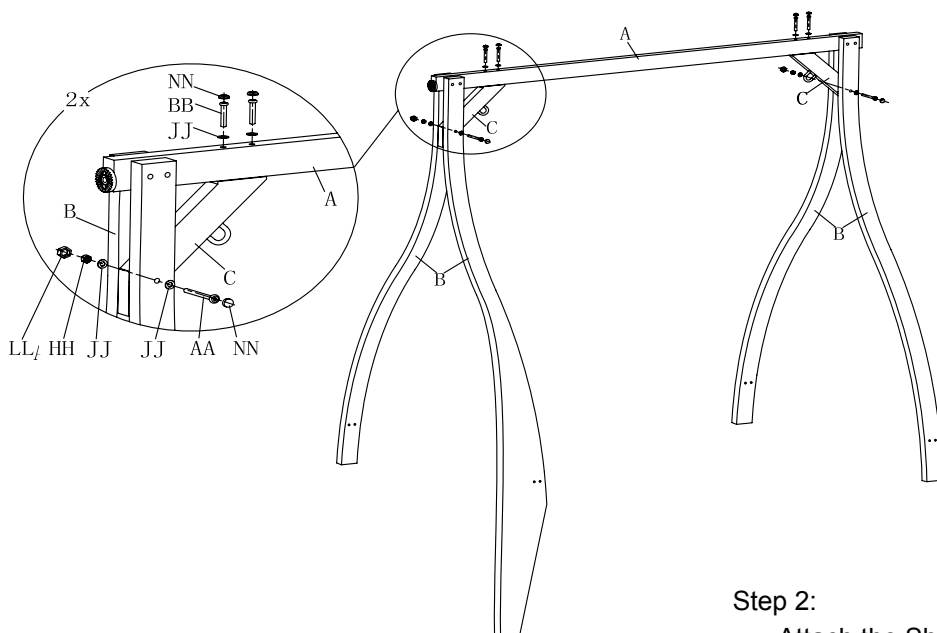

Step 2:

- Attach the Short Connector (C) to the Top Bar (A).
- Connect with M8 x 70 Bolt (BB), the M8 Washer (JJ) as shown in the picture.
- Loosely tighten by hand.
- Attach the Short Connector (C) to the Leg (B).
- Connect with M8 x 105 Bolt (AA), the M8 Washer (JJ) and the M8 Nut (HH) as shown in the picture.
- Loosely tighten by hand.

Questions, problems, missing parts? Before returning to your retailer, call our customer service department at (866) 905 - 4107, 8:30 a.m. - 5:00 p.m. PST/11:30 a.m. - 8:00 p.m., EST, Monday - Friday.

Walmart Assembly Instruction

TUSCANY 2PERSON PATIO SWING

Vendor stock No.: GCS00283D

NOTE: The M8 Bolt Cover (LL), M6 Bolt Cover (MM), M8 PLASTIC Cap (NN), M6 PLASTIC Cap (OO) in step 1 to 8 are only for reference. Please attach them to bolts in step 9.

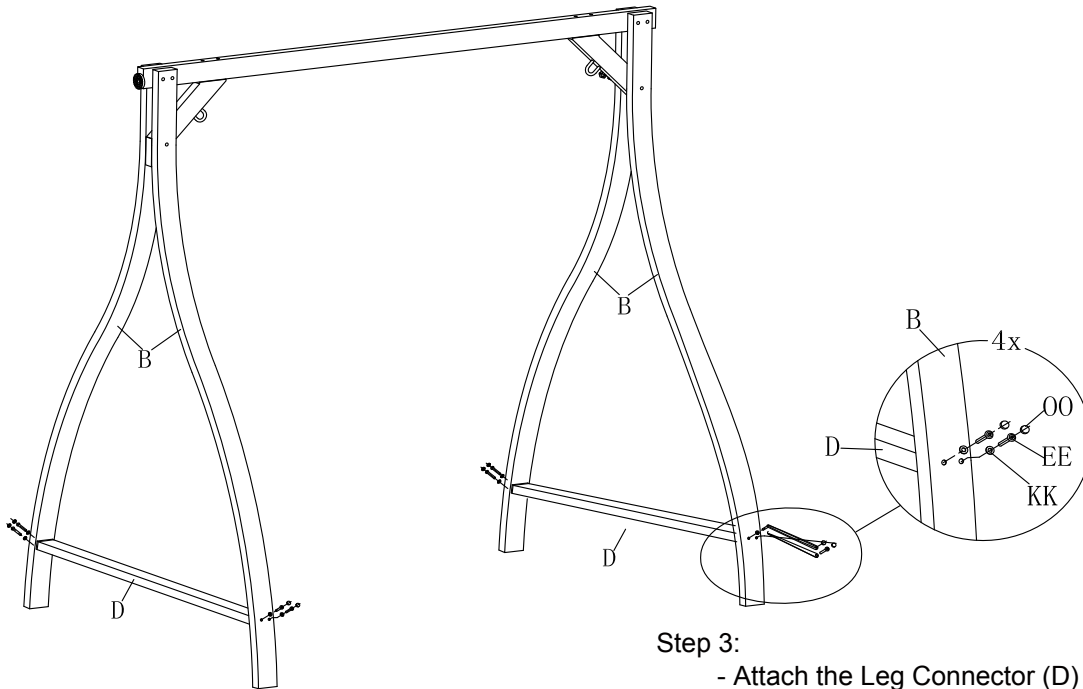

Step 3:

- Attach the Leg Connector (D) to the Leg (B).
- Connect with M6 x 40 Bolt (EE), the M6 Washer (KK) as shown in the picture.
- Tighten all the bolts from step 1 to step 3 with Allen Wrench(QQ) and Wrench (RR).

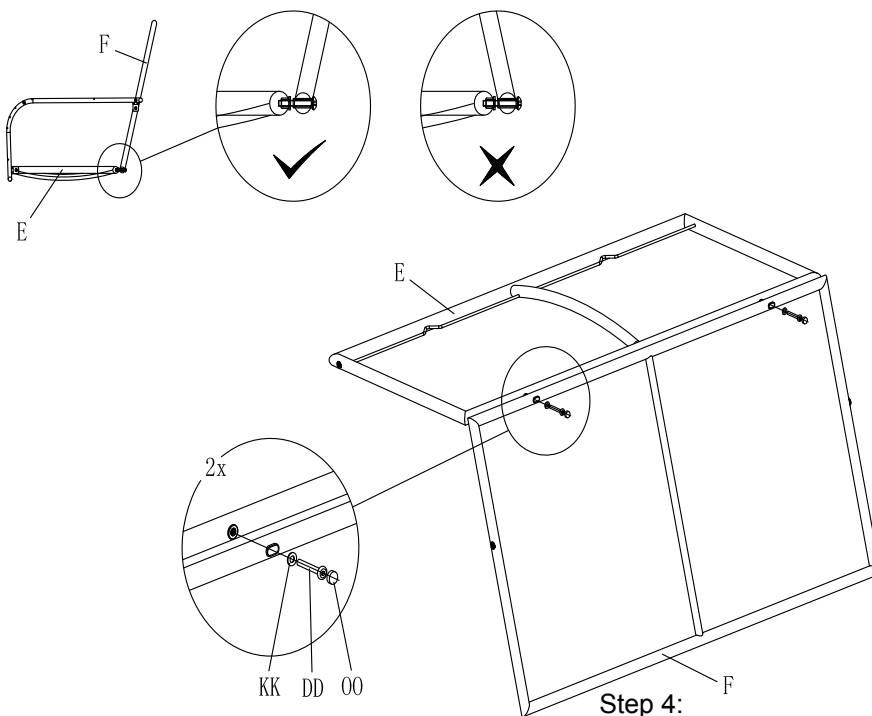

Step 4:

- Attach the Seat (F) and Back (E) at right angle as shown in the picture.
- Connect with M6 x 50 Bolt (DD), the M6 Washer (KK) as shown in the picture.

Questions, problems, missing parts? Before returning to your retailer, call our customer service department at (866) 905 - 4107, 8:30 a.m. - 5:00 p.m. PST/11:30 a.m. - 8:00 p.m., EST, Monday - Friday.

Walmart Assembly Instruction

TUSCANY 2PERSON PATIO SWING

Vendor stock No.: GCS00283D

NOTE: The M8 Bolt Cover (LL), M6 Bolt Cover (MM), M8 PLASTIC Cap (NN), M6 PLASTIC Cap (OO) in step 1 to 8 are only for reference. Please attach them to bolts in step 9.

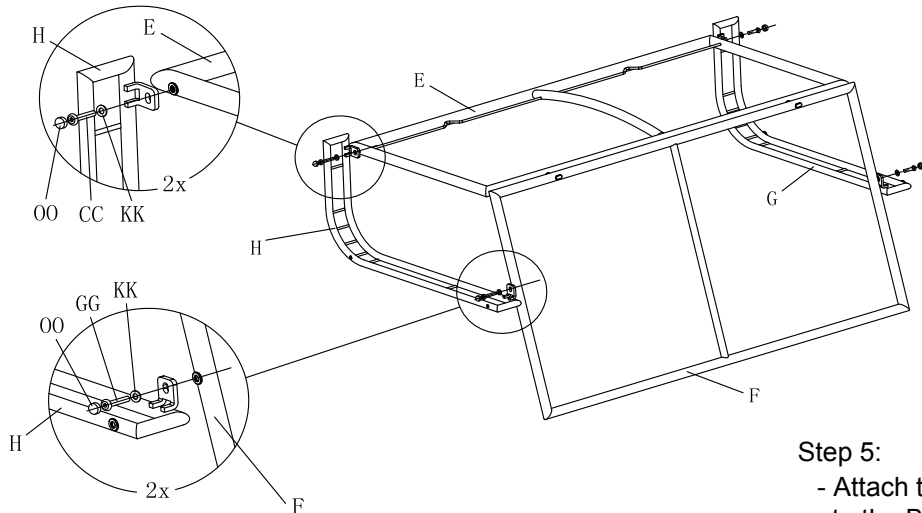

Step 5:

- Attach the Right Arm (G) and Left Arm (H) to the Back (F).
- Connect with M6 x 20 Bolt (GG), the M6 Washer (KK) as shown in the picture.
- Tighten all the bolts from step 4 to step 5 with Allen Wrench (QQ) and Wrench (RR).

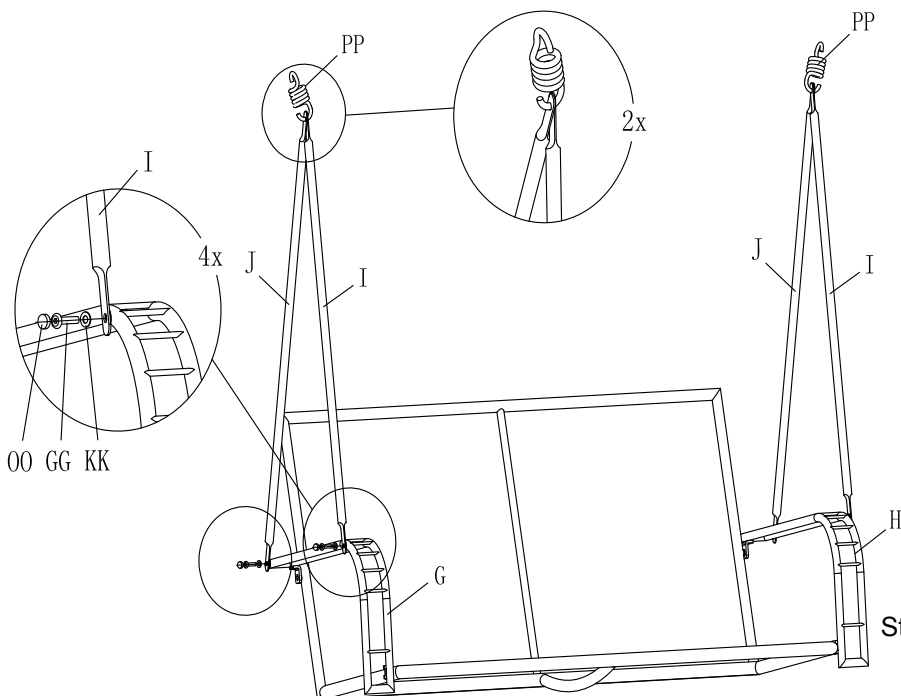

Step 6:

- Attach the Short Hanging Bar (I) & Long Hanging Bar (J) to Right Arm (G) and Left Arm (H) With M6 x 20 Bolt (GG) and M6 Washer (KK) as shown in the picture.
- Bring the holes in the free ends of Short Hanging Bar (I) & Long Hanging Bar (J) together and thread them onto the Hook (PP).
- Tighten all the bolts with Allen Wrench (QQ) and Wrench (RR).

Questions, problems, missing parts? Before returning to your retailer, call our customer service department at (866) 905 - 4107, 8:30 a.m. - 5:00 p.m. PST/11:30 a.m. - 8:00 p.m., EST, Monday - Friday.

Walmart Assembly Instruction

TUSCANY 2PERSON PATIO SWING

Vendor stock No.: GCS00283D

NOTE: The M8 Bolt Cover (LL), M6 Bolt Cover (MM), M8 PLASTIC Cap (NN), M6 PLASTIC Cap (OO) in step 1 to 8 are only for reference. Please attach them to bolts in step 9.

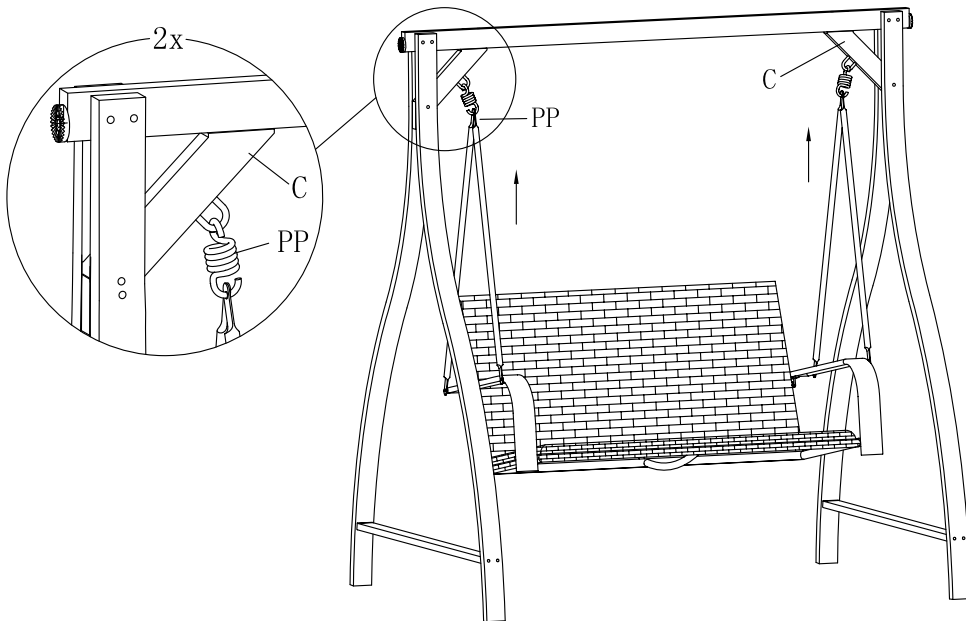

Step 7:

- Hang the Hook (PP) in the holes on the Short Connector (C).

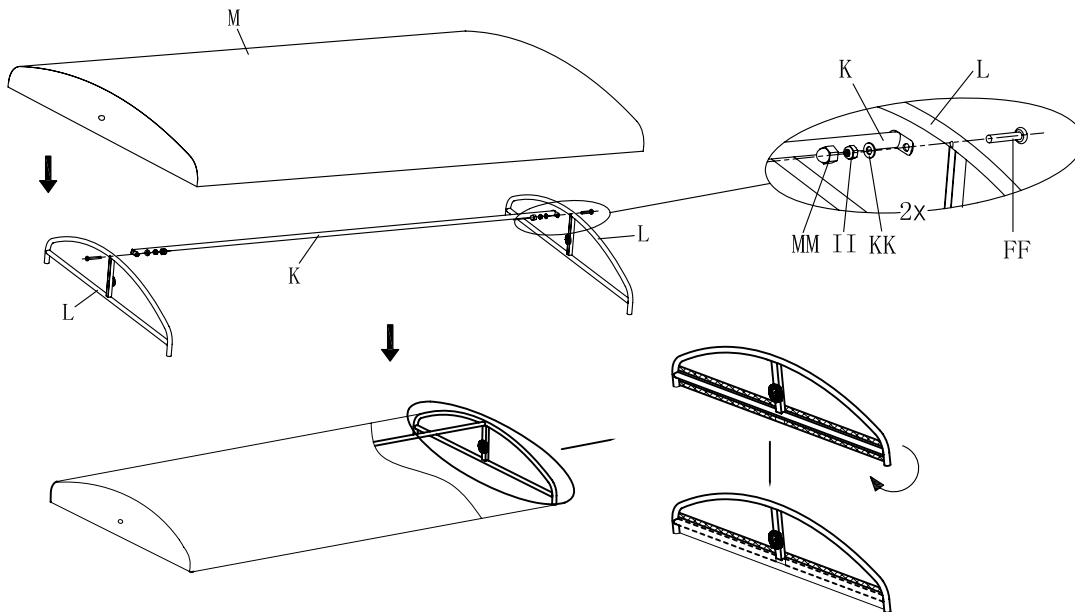

Step 8:

- Attach the Top Straight Bar (K) to the Top Curved Bars (L) with M6 x 30 Bolt (FF) and M6 Washer (KK) and the M6 Nut (II) as shown in the picture.
- Loosely tighten by hand first, then completely tighten with Allen Wrench (QQ).
- Place the Canopy (M) to the assembled top frame and tie the Canopy (M) to the Top Curved Bar (L) by affixing the velcro.

Questions, problems, missing parts? Before returning to your retailer, call our customer service department at (866) 905 - 4107, 8:30 a.m. - 5:00 p.m. PST/11:30 a.m. - 8:00 p.m., EST, Monday - Friday.

Walmart Assembly Instruction

TUSCANY 2PERSON PATIO SWING

Vendor stock No.: GCS00283D

NOTE: The M8 Bolt Cover (LL), M6 Bolt Cover (MM), M8 PLASTIC Cap (NN), M6 PLASTIC Cap (OO) in step 1 to 8 are only for reference. Please attach them to bolts in step 9.

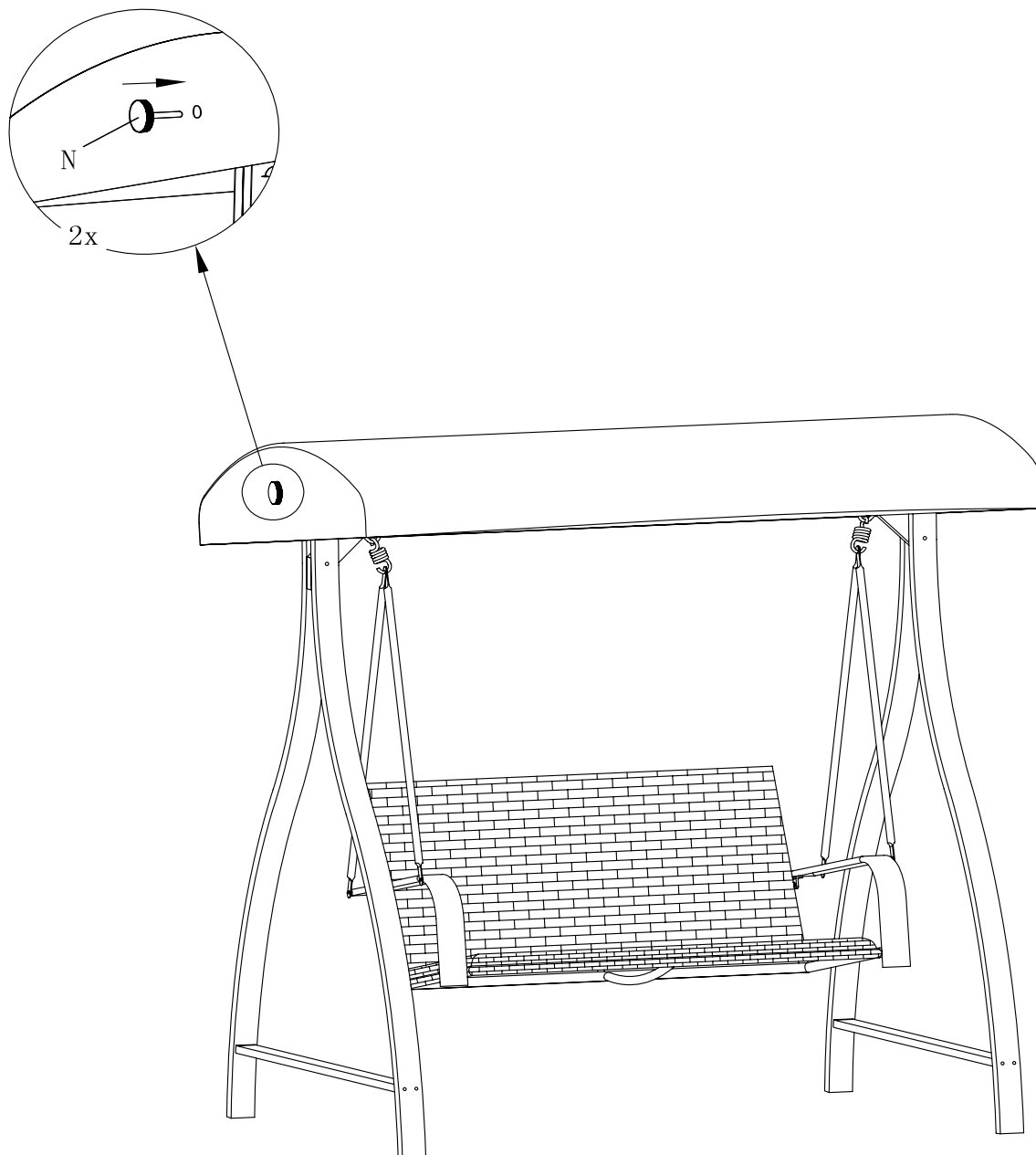

Step 9:

- Attach the assembled canopy on both sides to the Top Bar (A).
- Insert the Knob (N), turning the Knob (N) clockwise tightly.
- Ensure all connections are secure before use.
- Attach the M8 Bolt Cover (LL), M6 Bolt Cover (MM), M8 Plastic Cap (NN) and M6 Plastic Cap (OO) to all the bolts as shown in previous steps.

Questions, problems, missing parts? Before returning to your retailer, call our customer service department at (866) 905 - 4107, 8:30 a.m. - 5:00 p.m. PST/11:30 a.m. - 8:00 p.m., EST, Monday - Friday.