

DO NOT RETURN TO RETAILER

IF YOU HAVE ANY QUESTIONS OR CONCERNS
PLEASE VISIT OUR WEBSITE AT:

www.yotrioint.com

OR TOLL FREE AT:

1-866-905-4107

MONDAY-FRIDAY 8:30 AM TO 5:00 PM PACIFIC STANDARD TIME / 11:30
AM TO 8:00PM EASTERN STANDARD TIME

YOTRIO CUSTOMER CARE

Warranty Coverage Requirements:

1. Copy of your Original Store Receipt.
2. Pictures of the damaged parts.
3. You must know the name of your product and any corresponding item numbers as well as the name of the store where you purchased the item.
4. Please gather all of this information BEFORE you call customer service.

CARE AND MAINTENANCE

- ❖ Before using, wipe the product completely with a soft, dry cloth.
- ❖ Spot-clean Cushions and slings using a sponge, mild soap and water. Rinse thoroughly with clean water. To prevent mildew, allow to air dry completely before using or storing.
- ❖ Never machine wash or tumble dry cushions, slings or umbrella covers as this will result in shrinkage or damage.
- ❖ Rinse wicker patio furniture with a hose or pressure washer. If the wicker is really dirty, you can use mild soap with water. Allow to dry completely before using or storing.
- ❖ To clean your patio umbrella, use a soft brush and mild soap and water. Allow to dry completely before storing.
- ❖ Avoid placing hot objects directly onto table top surface without a heat protector.
- ❖ Always store and/or cover your patio furniture in a cool dry place when not in used and away from direct sunlight.
- ❖ When storing, never wrap cushions in plastic. Plastic doesn't allow the cushion to breathe and can cause it to mildew if there's any moisture present.
- ❖ Always place your patio furniture away from fire, extreme heat, freezing conditions and inclement weather such as rain, hail, sleet, snow or wind.
- ❖ Never use bleach or strong solvents to clean as this will cause damage to both fabric and metal finishes.
- ❖ Do not allow water to build up in frames as this will cause corrosion and damage.

ONE-YEAR FRAME AND ONE-YEAR FABRIC/WICKER/FINISH ETC. LIMITED WARRANTY

You must retain the original receipt to obtain warranty service.

- ❖ Frames are warranted against defects in materials and workmanship for a period of one year from the date of original purchase.
This warranty does not cover damage to frames or welds due to commercial use, improper assembly, acts of nature, fire, freezing and abusive use.
- ❖ Rust, corrosion, and/ or rust stains are not covered by warranty.
- ❖ Purchased parts are not covered under this warranty.
- ❖ Fabric on cushions, slings and umbrella is warranted one year against separation at the seams.
Fading, mildew, and color discoloration due to exposure to the elements, chemicals and spills are not covered.
- ❖ The Powder coat and/ or paint are warranted one year against blistering, peeling, or crackling.
Fading due to exposure to elements, chemicals and spills is not covered. Scratches and chips due to normal wear and use are not covered.
- ❖ Wicker Weave are warranted one year against breakage, separation, or tearing.
Fading or discoloration due to exposure from chemicals, spills and/ or the elements is not covered.
- ❖ Warranty covers free replacement of item within one year of purchase. After the one year it remains the customer's responsibility for freight and packaging charges to and from our service center.
- ❖ We do not compensate the individual or any outside party for assembling or disassembling the product.
- ❖ Any replacement of warranted items will be in the original style and color, or similar style and color if the original is un-available or has been discontinued.
Questions, problems, missing parts? Before returning to your retailer, call our customer service department at (866) 905-4107, 8:30 a.m. – 5:00 p.m. PST /11:30 a.m.- 8:00 p.m., EST, Monday- Friday.

Wal-mart.Com Assembly Instruction

Tuscany 3pc Wicker Nesting Side Table, Large

Stock# FWS70363ST

NOTE: Do not completely tighten bolts until all steps are completed.





PART NO.	PICTURE	DESCRIPTION	QTY
A		Table Top	1
B		Connecting Part	1
C		Table Leg A	2
D		Table Leg B	2
AA		M6x15 Bolt & Washer	12
BB		Allen Wrench	1

Fig. 1

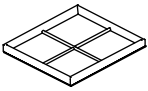
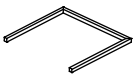

Step 1: Place the table top (A) on the carton and attach the table leg A (C) and the table leg B (D). Line up the corresponding holes on the four table legs (C&D) and the table top (A), and insert M6x15 bolt & washer (AA), loosely tighten with the allen wrench (BB). Do not over tighten. Please see Fig. 1.

Fig. 2

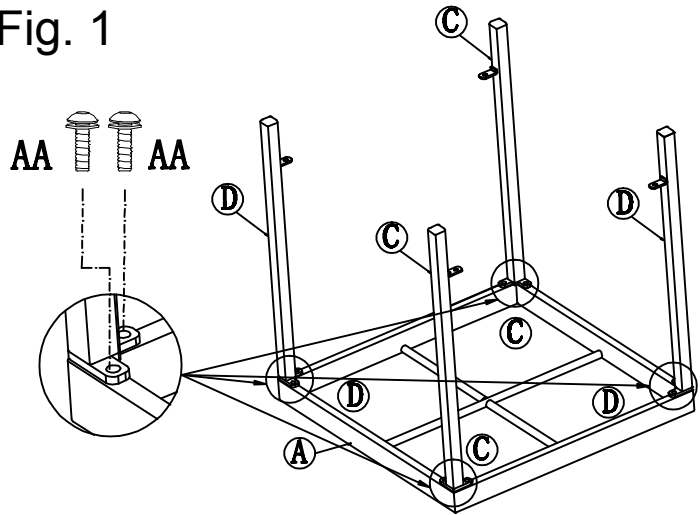
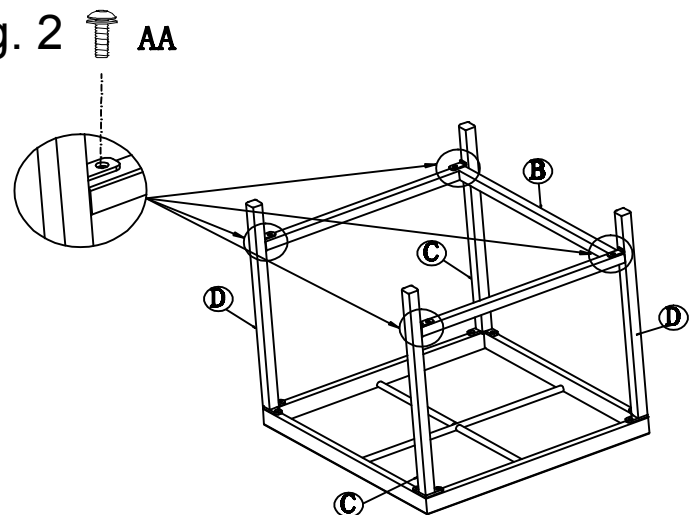

Step 2: Place the connecting part (B) between the four legs (C&D). Line up the corresponding holes on the connecting part and the four legs, and insert M6x15 bolt with washer (AA), loosely tighten with the allen wrench (BB). Do not over tighten. Please see Fig. 2.

Fig. 3

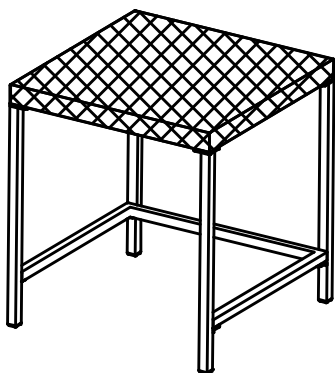

Step 3: After all the bolts are inserted, fully tighten all the bolts. Turn the side table right side up, and check alignment of the table legs and adjust as needed. Ensure all the connections are secure before use. Please see Fig. 3.

Questions, problems, missing parts? Before returning to your retailer, call our customer service department at (866) 905 - 4107, 8:30 a.m. - 5:00 p.m. PST/11:30 a.m. - 8:00 p.m., EST, Monday - Friday.

Wal-mart.Com Assembly Instruction

Tuscany 3pc Wicker Nesting Side Table, Medium & Small

Stock# FWS70363ST

NOTE: Do not completely tighten bolts until all steps are completed.





PART NO.	PICTURE	DESCRIPTION	QTY
A		Table Top	1
B		Connecting Part	1
C		Table Leg A	2
D		Table Leg B	2
AA		M6x15 Bolt & Washer	12
BB		Allen Wrench	1

Fig. 1

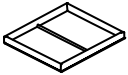
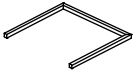

Step 1: Place the table top (A) on a soft surface. Attach the table leg A (C) and the table leg B (D). Line up the corresponding holes on the four table legs (C&D) and the table top (A), and insert M6x15 bolt & washer (AA), loosely tighten with the allen wrench (BB). Do not over tighten. Please see Fig. 1.

Fig. 3

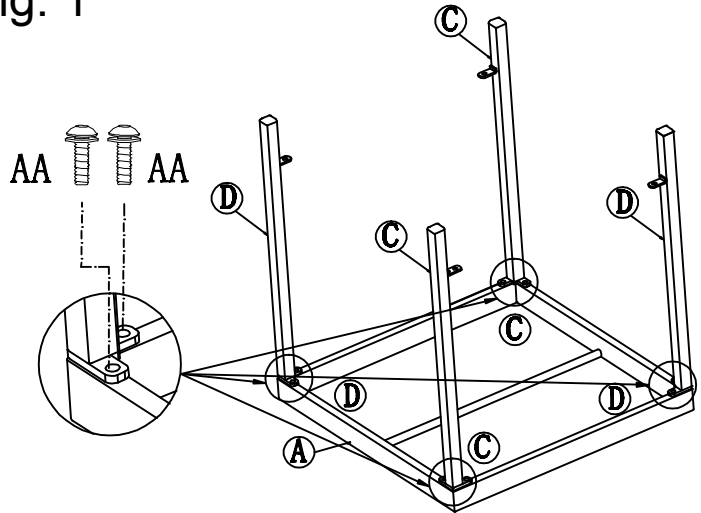
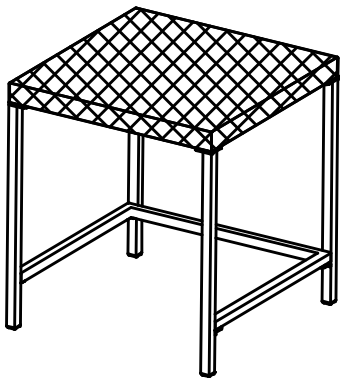

Step 3: After all the bolts are inserted, fully tighten all the bolts. Turn the side table right side up, and check alignment of the table legs and adjust as needed. Ensure all the connections are secure before use. Please see Fig. 3.

Fig. 2

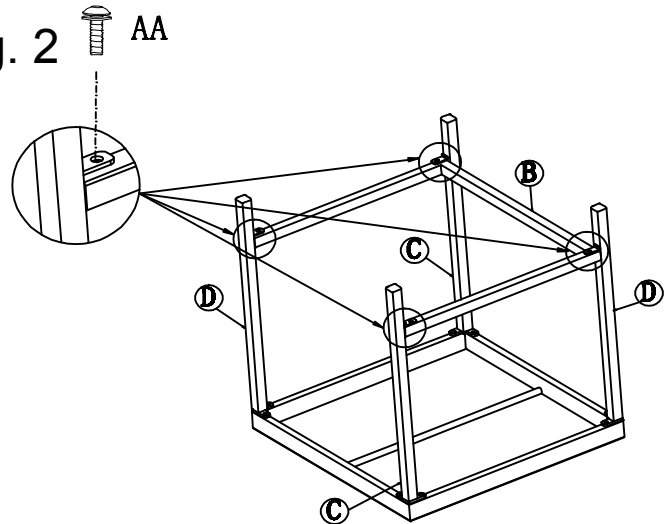

Step 2: Place the connecting part (B) between the four legs (C&D). Line up the corresponding holes on the connecting part and the four legs, and insert M6x15 bolt & washer (AA), loosely tighten with the allen wrench (BB). Do not over tighten. Please see Fig. 2.