

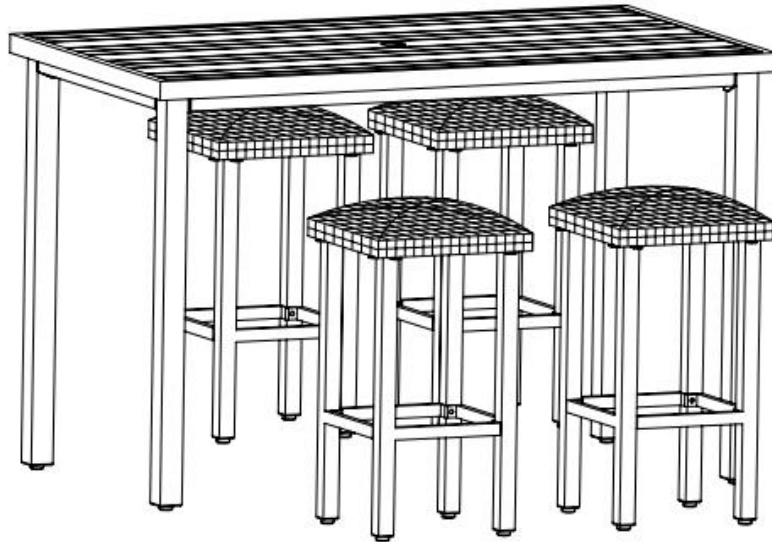



ASSEMBLY INSTRUCTIONS:

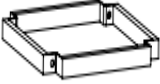

5 PC DINING SET

SKU#68586478



COMPONENTS			
PART	FIGURE	DESCRIPTION	QTY
A		SEAT CUSHION	1
B		CONNECTOR RING	1
C		LEG	4

HARDWARE TOOLS			
PART	FIGURE	DESCRIPTION	QTY

AA		M6*20 BOLT WITH WASHER	12
BB		ALLEN WRENCH	1

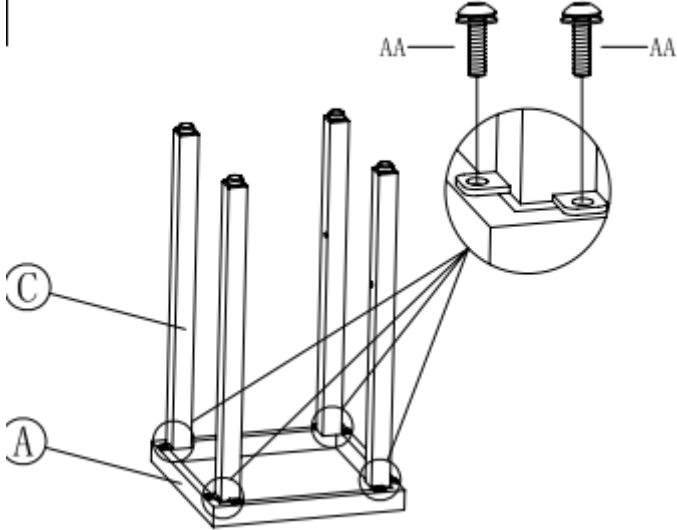
STEP	
1	<p>Place the Seat Cushion (A) on a flat, protected surface. Attach the table Leg (B) to the Seat Cushion (A) by using M6*20 Bolt with Washer (AA). Hands tighten only. Use the Allen Wrench (BB) to tighten all bolts. Do not over tighten. Over tightening may strip bolts and washes.</p>
	<p>STEP 1</p> 
2	<p>Attach the Connector Ring (C) to the table Leg (B) by using M6*20 Bolt with Washer (AA). Hands tighten only.</p>

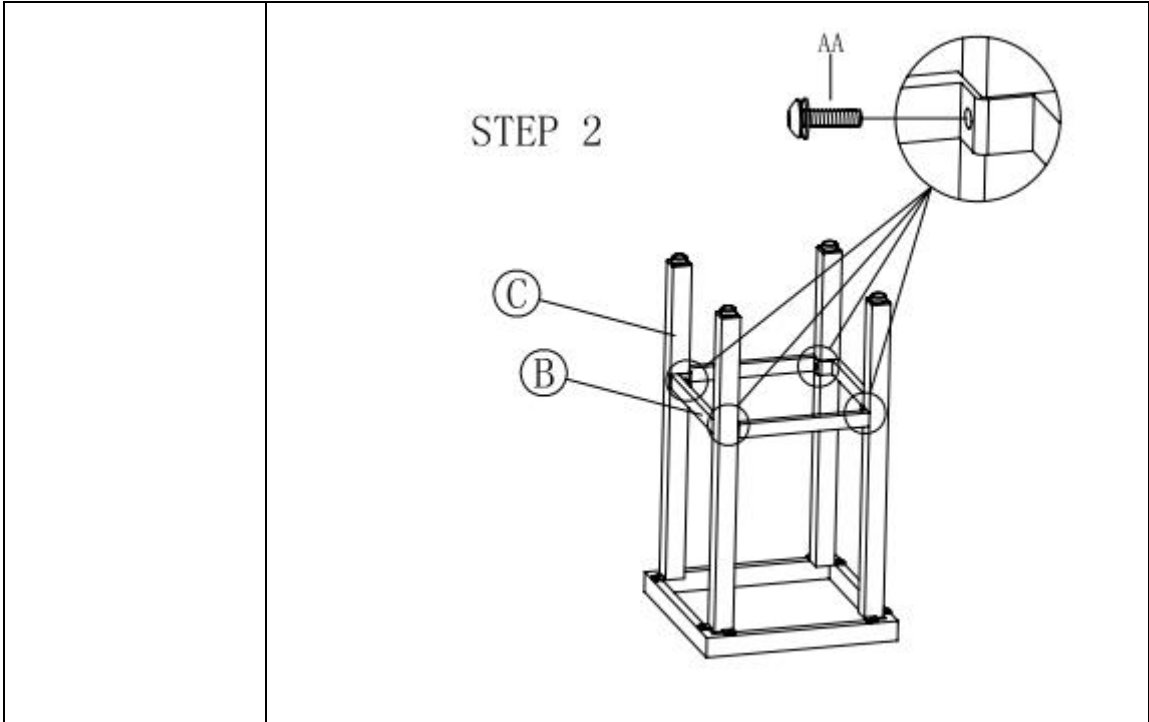



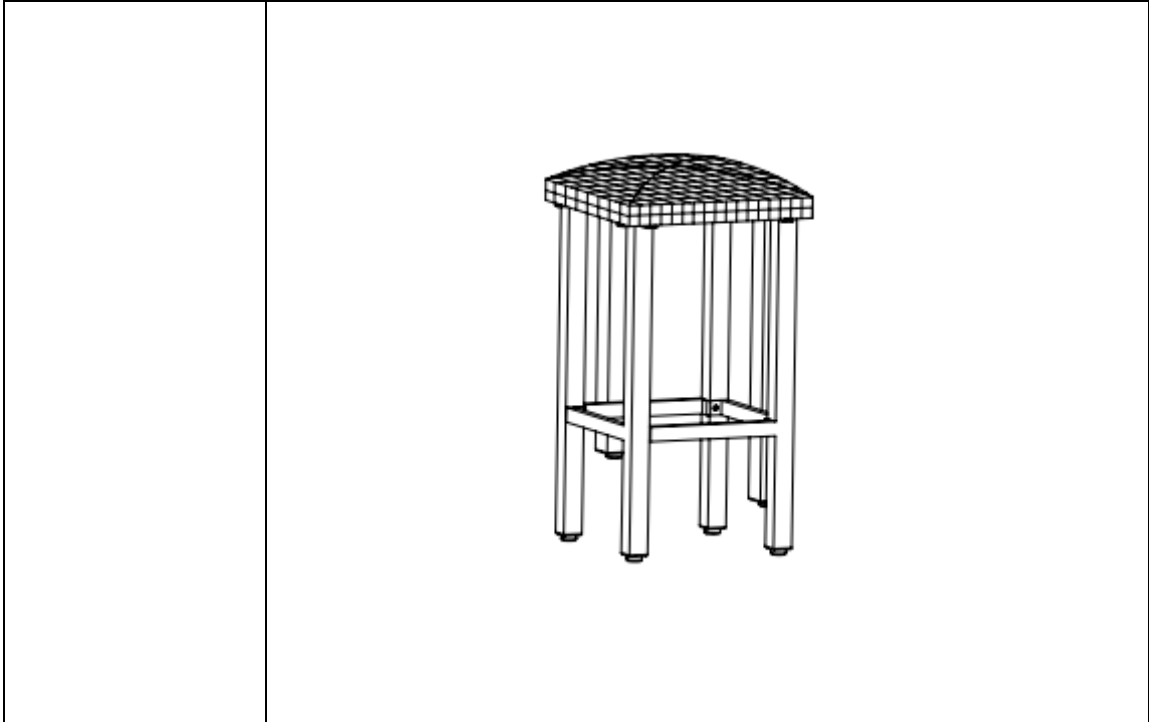

3 Place the Seat in the upright position.
Assembly is Completed.

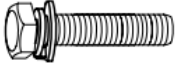

TABLE

COMPONENTS			
PART	FIGURE	DESCRIPTION	QTY

A		TABLE TOP	1
B		TABLE LEG	4
HARDWARE TOOLS			
PART	FIGURE	DESCRIPTION	QTY
AA		M8*35 BOLT WITH WASHER	8
BB		WRENCH	1

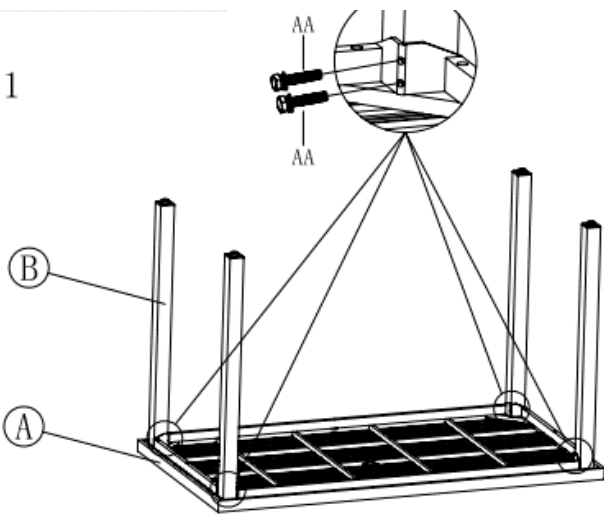
STEP	
1	<p>Place the Table Top (A) on a flat, protected surface. Attach the table Leg (b) to the Table Top (A) by using M6*35 Bolt with Washer (AA). Hands tighten only. Use the Wrench (BB) to tighten all bolts. Do not over tighten. Over tightening may strip bolts and washes.</p>
	<p>STEP 1</p> 



2	Place the Slat table in the upright position. Assembly is Completed.
	

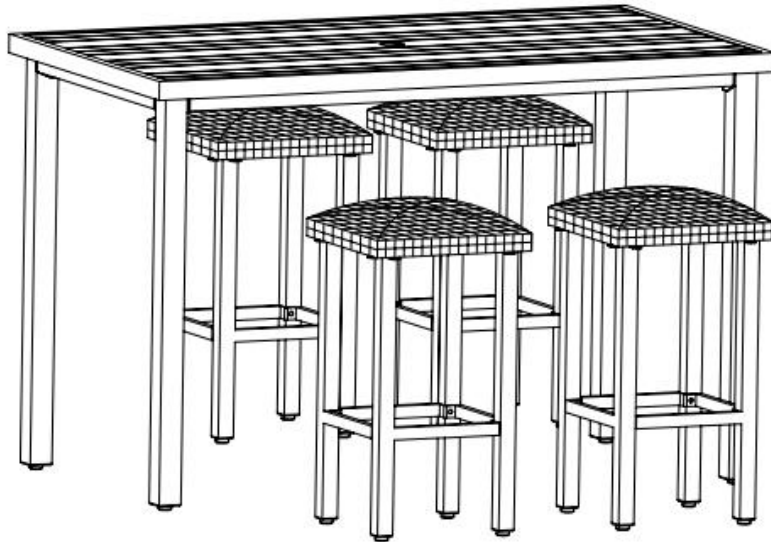

Cleaning and Maintenance

- Clean with mild soap and water, rinse thoroughly, and dry completely.
Do not use bleach, acid, or other solvents on this item
- We recommend the use of furniture covers to protect this item when not in use.
- Inspect and tighten all bolts on a regular basis to ensure proper performance and safety.
- In order to prolong the life and beauty of your item, we recommend storing it in a dry and protected area during off season periods.

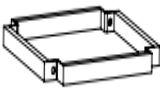
DIRECTIVES D'ASSEMBLAGE :
ENSEMBLE DE 5 PIÈCES POUR SALLE À MANGER
N° d'UGS : 68586478



COMPOSANTES			
PIÈCE	FIGURE	DESCRIPTION	QTÉ
A		COUSSIN DE SIÈGE	1
B		ANNEAU DE SOUTIEN	1
C		PIED	4

QUINCAILLERIE ET OUTILS			
PIÈCE	FIGURE	DESCRIPTION	QTÉ
AA		BOULON M6 x 20 mm AVEC RONDELLE	12
BB		CLÉ HEXAGONALE	1

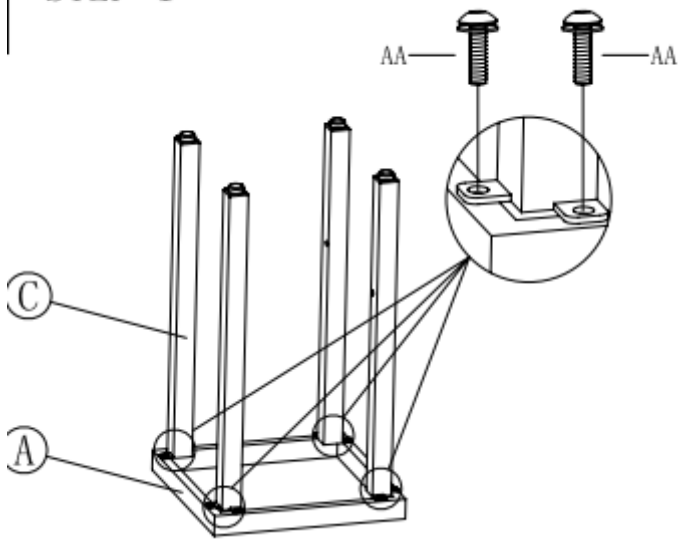
ÉTAPE	
1	<p>Poser le coussin de siège (A) sur une surface plate et protégée. Fixer le pied (B) au coussin de siège (A) à l'aide d'un boulon M6 x 20 mm avec rondelle (AA). Serrer à la main seulement.</p> <p>Utiliser la clé hexagonale (BB) pour serrer tous les boulons. Ne pas trop serrer. Trop serrer risque de détruire le pas des boulons et des rondelles.</p>
	<p>STEP 1</p> 



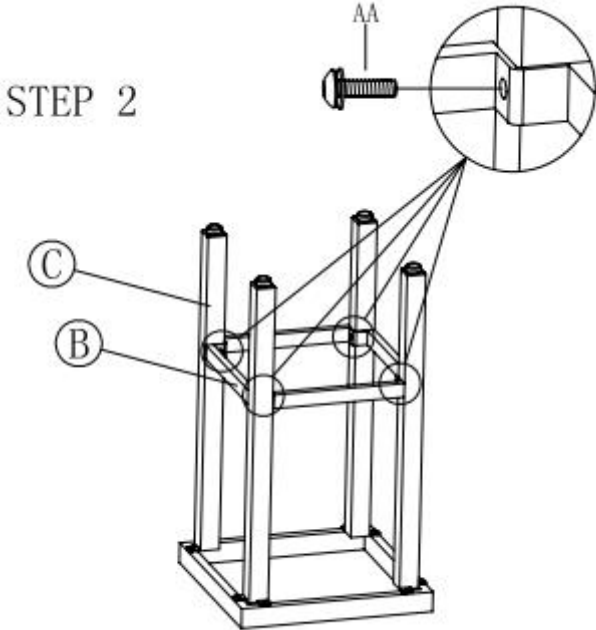

2 Fixer l'anneau de soutien (C) au pied (B) à l'aide d'un boulon M6 x 20 mm avec rondelle (AA). Serrer à la main seulement.

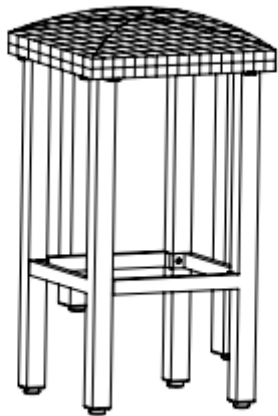

3 Placer le siège en position verticale. L'assemblage est terminé.

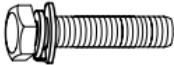

TABLE

COMPOSANTES			
PIÈCE	FIGURE	DESCRIPTION	QTÉ
A		DESSUS DE TABLE	1
B		PIED DE TABLE	4
QUINCAILLERIE ET OUTILS			
PIÈCE	FIGURE	DESCRIPTION	QTÉ
AA		BOULON M8 x 35 mm AVEC RONDELLE	8
BB		CLÉ	1

ÉTAPE	
1	<p>Poser le dessus de table (A) sur une surface plate et protégée. Fixer le pied de table (B) au dessus de table (A) à l'aide d'un boulon M6 x 35 mm avec rondelle (AA). Serrer à la main seulement.</p> <p>Utiliser la clé (BB) pour serrer tous les boulons. Ne pas trop serrer. Trop serrer risque de détruire le pas des boulons et des rondelles.</p>

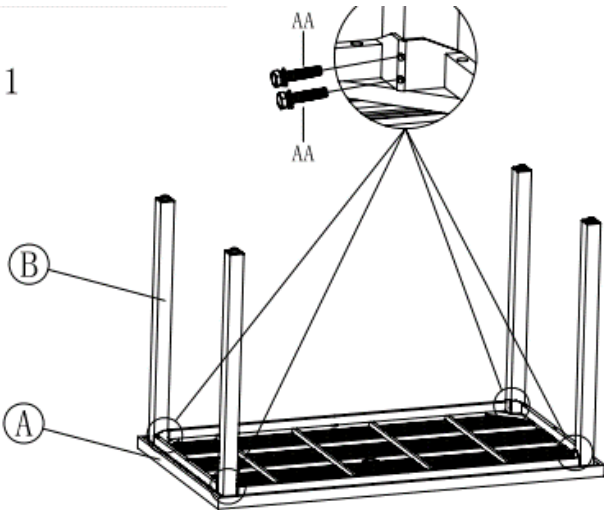
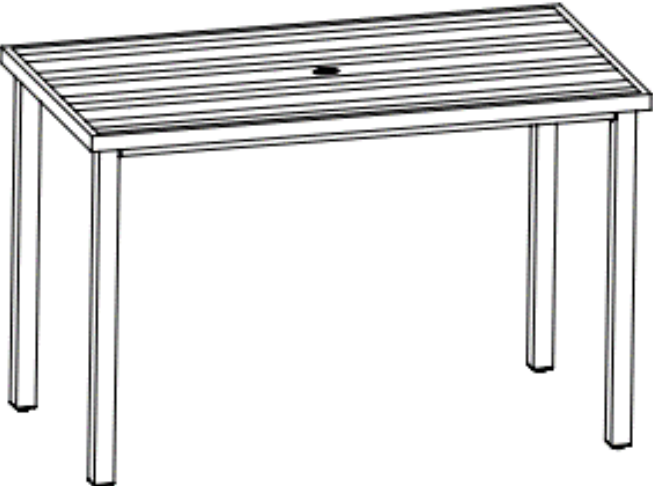
	<p>STEP 1</p> 
2	<p>Placer la table à lattes en position verticale. L'assemblage est terminé.</p>
	

Nettoyage et entretien



- Nettoyer avec de l'eau et du savon doux, bien rincer et sécher complètement.
Ne pas utiliser de javellisant, de détergent acide ou d'autres solvants sur cet article.
- Nous vous recommandons d'utiliser des housses à meubles pour protéger cet article entre les utilisations.
- Vérifier l'état de tous les boulons et les serrer régulièrement pour garantir le bon fonctionnement et l'aspect sécuritaire de l'article.
- Afin de prolonger la durée et la belle apparence de votre article, nous vous recommandons de le ranger dans un endroit sec et protégé pendant les périodes hors saison.

INSTRUCCIONES DE ENSAMBLAJE:

COMEDOR DE 5 PIEZAS

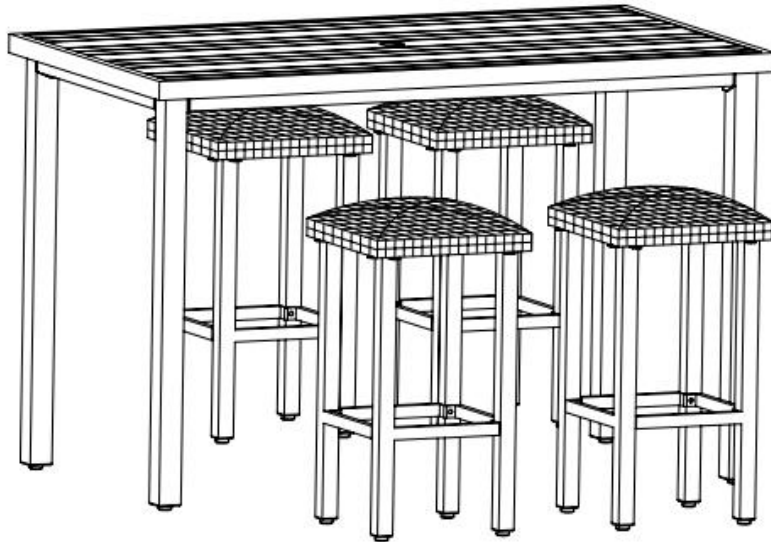
SKU#68586478

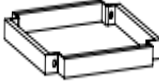

COMPONENTES			
PARTE	IMAGEN	DESCRIPCIÓN	CANTIDAD
A		ASIENTO	1
B		MARCO CONECTOR	1
C		PATA	4

EQUIPO DE ENSAMBLAJE			
PARTE	IMAGEN	DESCRIPCIÓN	CANTIDAD

AA		PERNO CON RONDANA M6*20	12
BB		LLAVE ALLEN	1

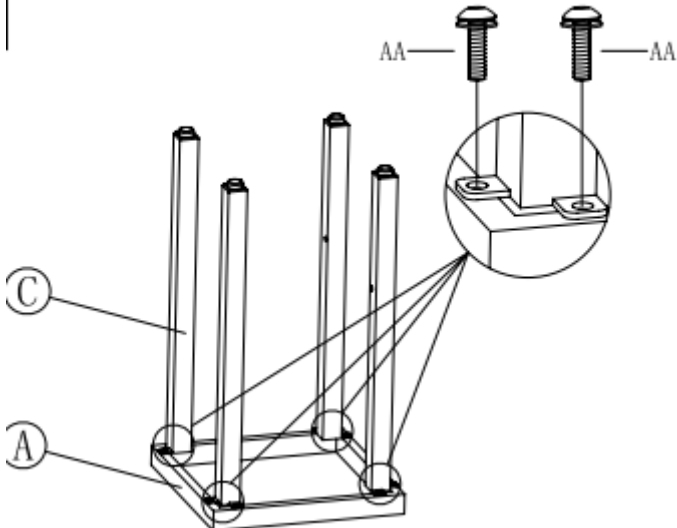
PASO	
1	<p>Coloque el asiento (A) sobre una superficie plana y protegida. Una las patas (B) del banco al asiento (A) utilizando pernos con rondanas M6*20 (AA). Ténselos con las manos.</p> <p>Use la llave Allen (BB) para tensar los pernos. No los tense de más. Tensarlos de más puede barrer los pernos y las rondanas.</p>
	<p>STEP 1</p> 
2	<p>Una el marco conector (C) a las patas del banco (B) usando pernos con rondanas M6*20 (AA). Ténselos con las manos.</p>

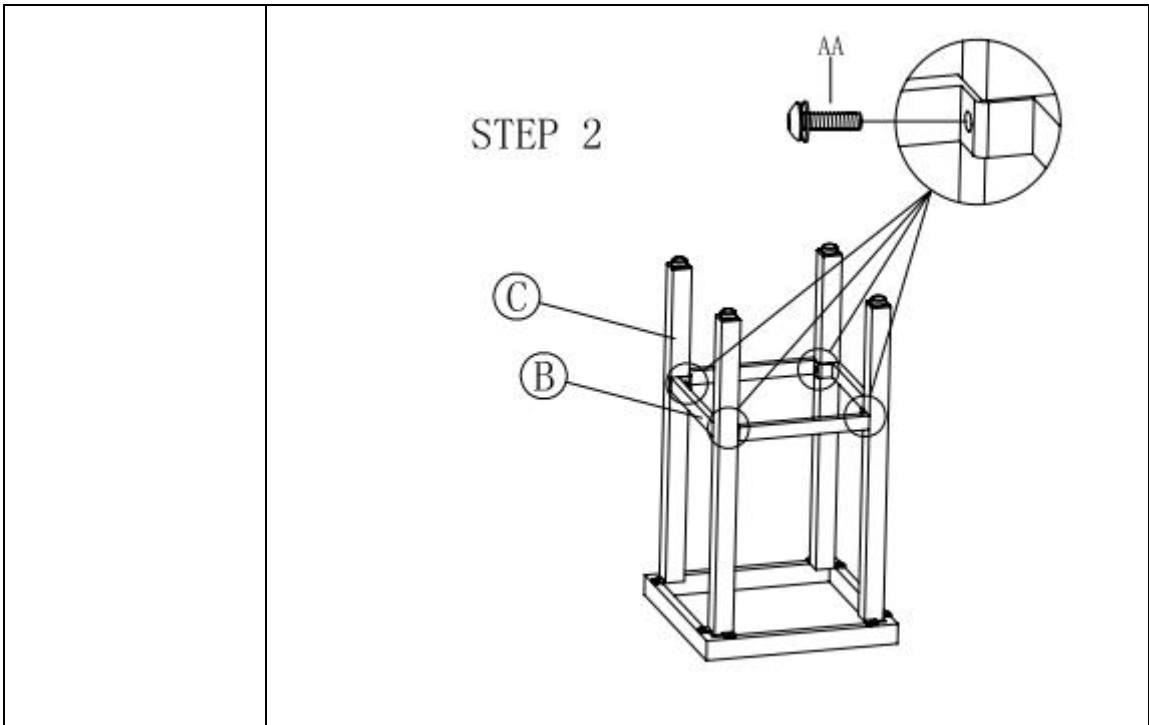

3 Coloque el banco en posición vertical.
Ha finalizado el ensamble.

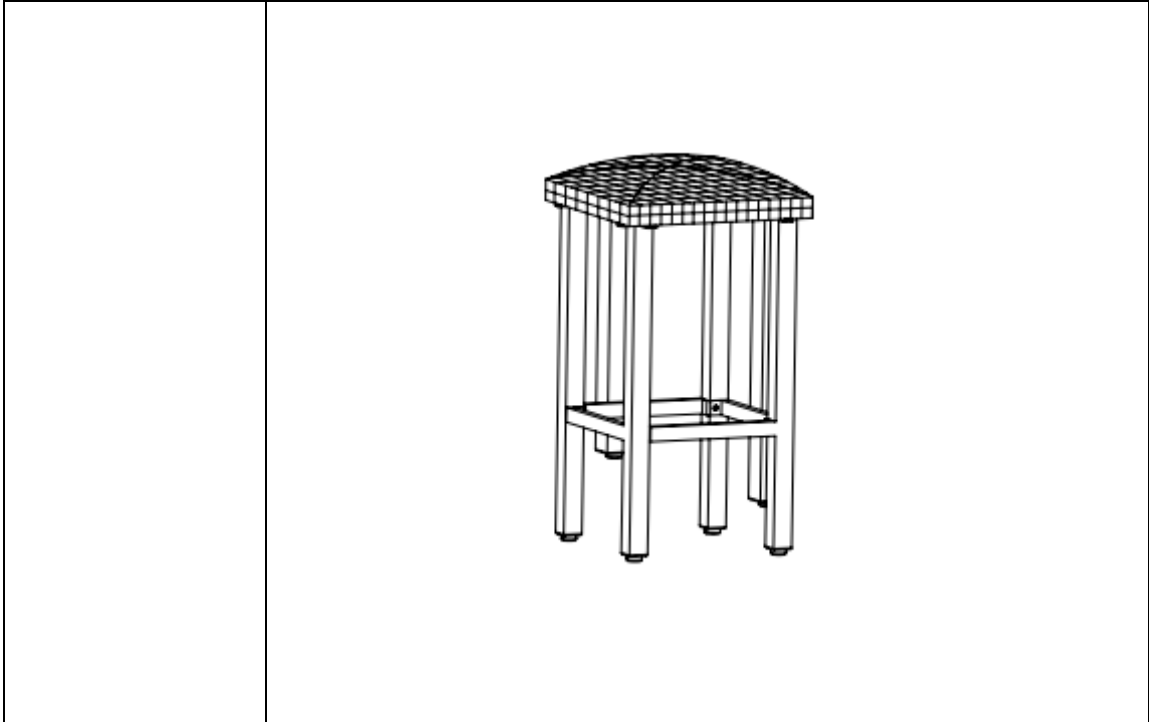



MESA

COMPONENTES			
PARTE	IMAGEN	DESCRIPCIÓN	CANTIDAD

A		SUPERFICIE DE MESA	1
B		PATA DE MESA	4
EQUIPO DE ENSAMBLAJE			
PARTE	IMAGEN	DESCRIPCIÓN	CANTIDAD
AA		PERNO CON RONDANA M8*35	8
BB		LLAVE	1

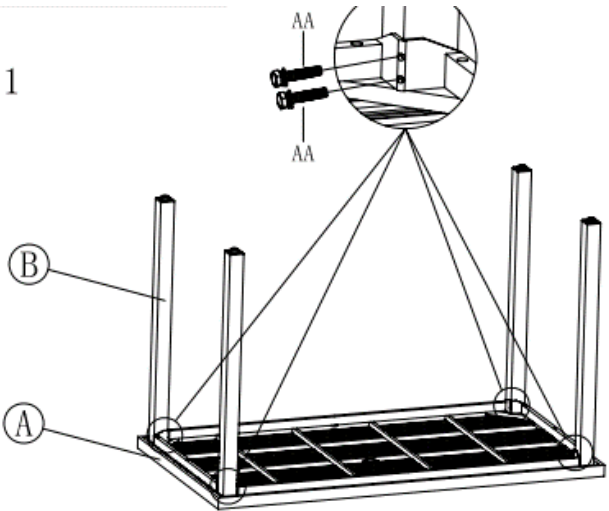
PASO	
1	<p>Coloque la superficie de la mesa (A) sobre una superficie plana y protegida. Una las patas (b) de la mesa a la superficie de la mesa (A) utilizando pernos con rondanas M6*35 (AA). Ténselos con las manos.</p> <p>Use la llave (BB) para tensar los pernos. No los tense de más. Tensarlos de más puede barrer los pernos y las rondanas.</p>

	<p>STEP 1</p> 
2	<p>Coloque la mesa en posición vertical. Ha finalizado el ensamblaje.</p>
	

Limpieza y mantenimiento

- Limpie con agua y jabón suave, enjuague y seque por completo.
No use blanqueador, ácido u otros solventes para limpiar este artículo.
- Recomendamos el uso de fundas para proteger el artículo cuando no esté en uso.
- Revise y tense periódicamente todos los pernos para garantizar un correcto desempeño y seguridad.
- Para prolongar la vida y estética del artículo, recomendamos guardarlo en un

área seca y protegida durante largos periodos sin uso.

PÁGINA 3 DE 3

Warning!

- Do not let any sharp objects touch or rub the surface of the product.
- When assembling, do not let children play around the working area.
- Please confirm all parts are correct before starting the assembly process.
- Do not tighten all bolts and screws completely until the entire unit has been assembled and set up.
- Use only the hex wrench provided. **DO NOT USE POWER TOOLS.**

Power tools can overtighten screws and strip threads

For each screw:

1. The washer must be next to the tube.
2. Tighten each screw until you meet resistance and spacer begins to push into the tube.
3. Tighten one additional full rotation. **DO NOT OVERTIGHTEN.**

Atención!

- No permita que ningún objeto afilado roce o toque la superficie del producto.
- No permita que hayan niños jugando alrededor mientras realiza la instalación.
- Por favor revise que todas las partes estén correctas antes de empezar con la instalación.
- No asegure los pernos y tornillos hasta que la unidad completa haya sido instalada y los ajustes se hayan establecido.
- Use solamente el Destornillador de cabeza hexagonal incluido.

NO UTILICE HERRAMIENTAS ELÉCTRICAS.

Las herramientas eléctricas pueden ajustar los tornillos demasiado y rasgar cables.

Para los tornillos:

1. Rondelle deben encontrarse al lado de la tuda.
2. Asegure cada tornillo hasta que sienta resistencia y los Espaciador empiecen a presionar la tuda.
3. Asegure hasta un poco más de lo aceptado. **No asegure los tornillos demasiado.**

Attention

- Ne laissez pas tout objet pointu de toucher ou de frotter la surface du produit.
- Lors de l'assemblage, de ne pas laisser les enfants jouer près de l'aire de travail.
- Veuillez confirmer que tous les éléments sont exacts avant d'entamer le processus d'assemblage.
- Ne pas serrer tous les boulons et vis complètement jusqu'à l'unité entière a été assemblé et mis en place.
- Utiliser les outils fournis. **Ne pas utiliser des outils électriques.**

Outils électriques peuvent renforcer des fils vis et bandes.

Pour chaque vis:

1. Arandela doit être à côté du tube.
2. Renforcer la résistance et chaque baiser jusqu'à ce que le espaceur commence à pousser dans le tube.
3. Une rotation supplémentaire. **Ne pas trop serrer.**