

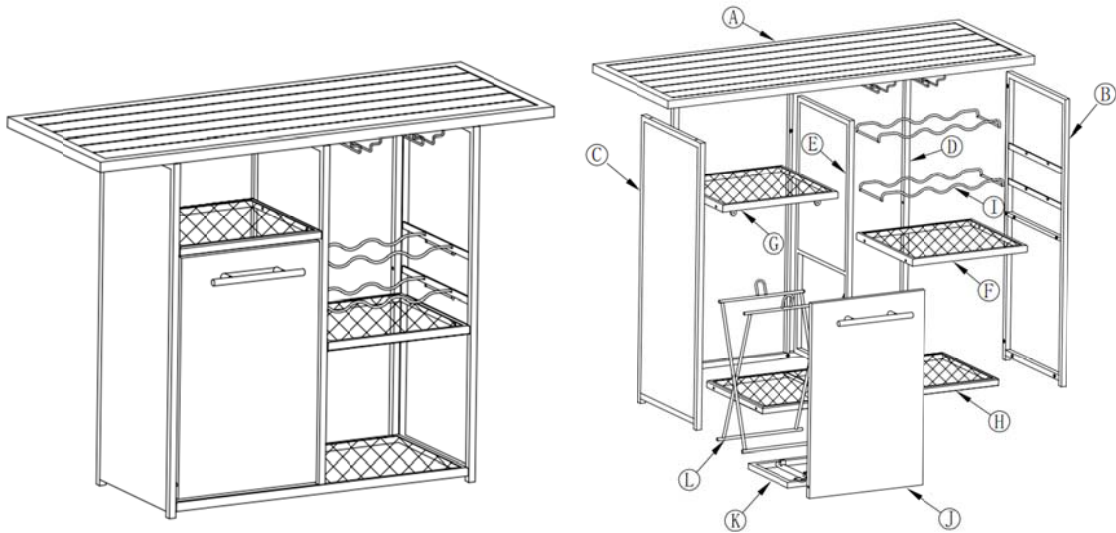

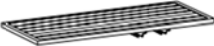

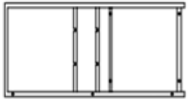





ASSEMBLY INSTRUCTIONS





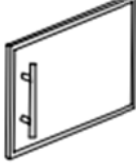
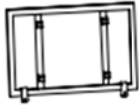

WICKER BAR



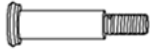





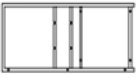

SKU# 68636371



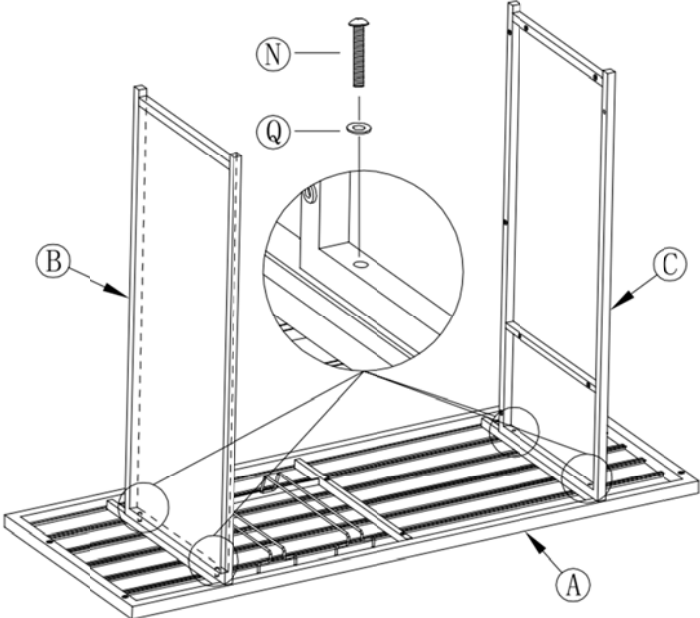





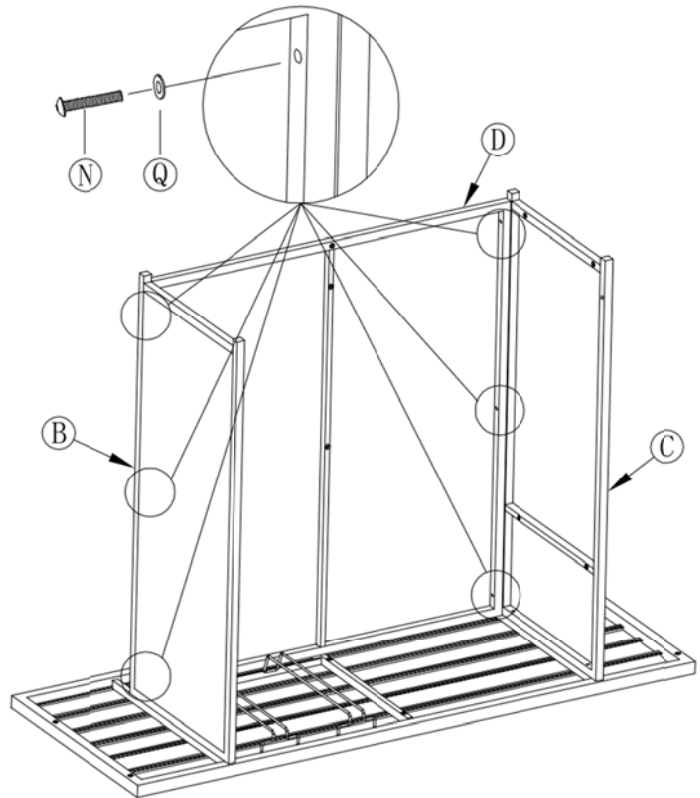







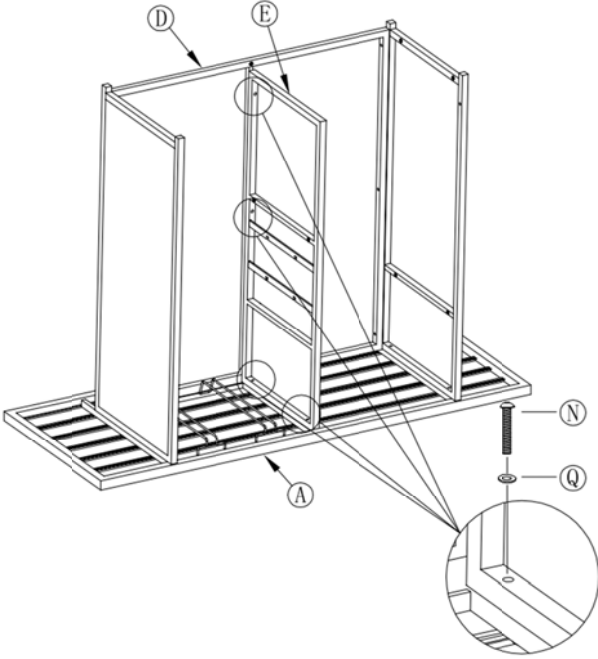
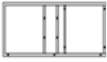







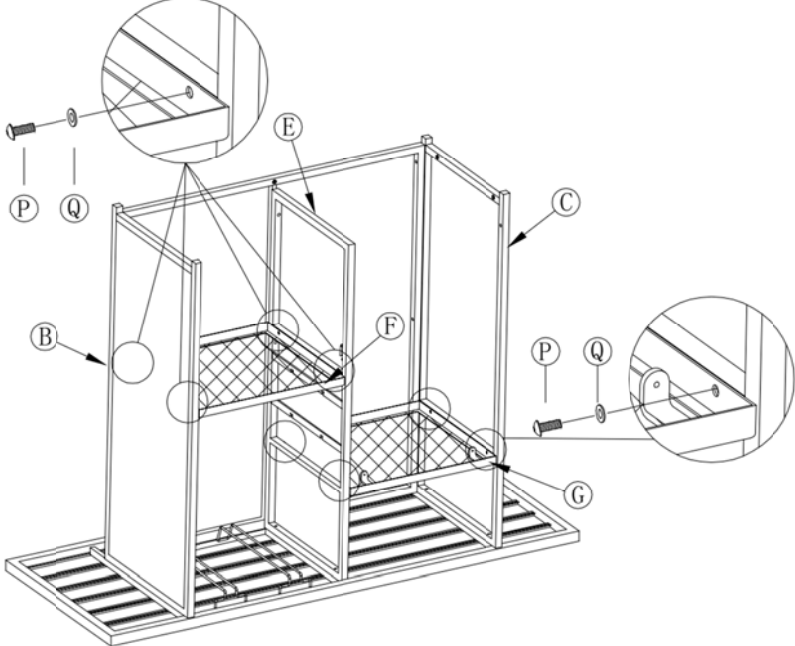

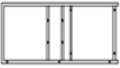
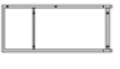

COMPONENTS			
PART	FIGURE	DESCRIPTION	QTY
A		TABLE TOP	1
B		RIGHT PANEL	1
C		LEFT PANEL	1
D		BACK PANEL	1
E		MIDDLE PANEL	1

COMPONENTS			
PART	FIGURE	DESCRIPTION	QTY
F		RIGHT SHELF	1
G		LEFT SHELF	1
H		BOTTOM SHELF	1
I		BOTTLE RACK	2
J		SIDEDOOR	1
K		DOOR'S BOTTOM SHELF	1
L		METAL FRAME	1

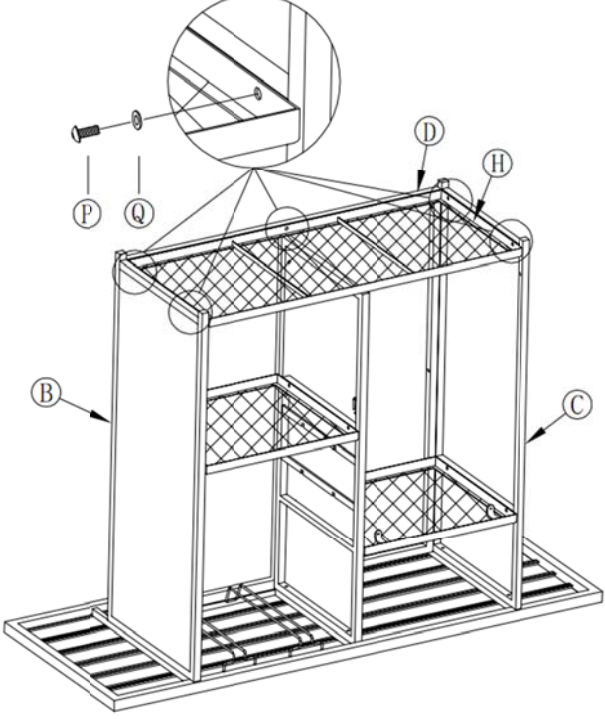
HARDWARETOOLS			
M		M0.24"*0.47" BOLT	2
N		M0.24"*1.38" BOLT	15
O		0.24"*0.79" BOLT	2
P		0.24"*0.6" BOLT	13
Q		WASHER	30
R		ALLEN WRENCH	1

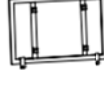
STEP	
1	Place the Table Top (A) face down on a non-abrasive surface. Attach Right Panel (B) and Left Panel (C) to the Table Top (A) by inserting Washers (Q) and M0.24"*1.38"Bolts (N). Hand tighten only.
<p>A. </p> <p>B. </p> <p>C. </p> <p>N. </p> <p>Q. </p> <p>R. </p>	
2	Attach the Back Panel (D) to the Right Panel (B) and Left Panel (C) by using Washers (Q) and M0.24"*1.38"Bolts (N).Hand tighten only.
<p>B. </p> <p>C. </p> <p>D. </p> <p>N. </p> <p>Q. </p> <p>R. </p>	

STEP	
3	<p>Attach the Middle Panel (E) to the Back Panel (D) and Table Top (A) by using Washers (Q) and M0.24"*1.38"Bolts (N).Hand tighten only.</p>
<p>A. </p> <p>D. </p> <p>E. </p> <p>N. </p> <p>Q. </p> <p>R. </p>	
4	<p>Attach the Right Shelf (F) to the Right Panel (B) and Middle panel (E) by using Washers (Q) and M0.24"*0.60"Bolts (P). Attach the Left Shelf (G) to the Left Panel (C) and Middle Panel (E) by using Washers (Q) and M0.24"*0.60"Bolts (P). Hand tighten only.</p>
<p>B. </p> <p>C. </p> <p>E. </p> <p>F. </p> <p>H. </p> <p>G. </p> <p>P. </p> <p>Q. </p> <p>R. </p>	

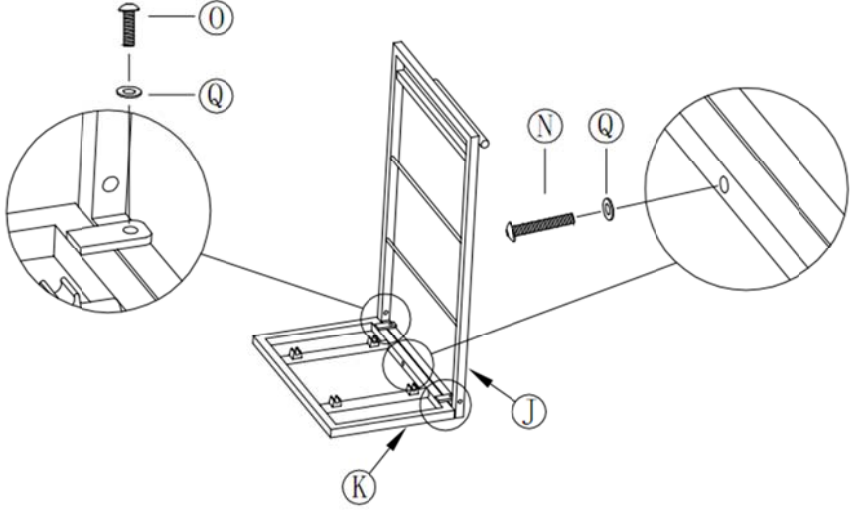
STEP	
5	<p>Connect the Bottom Shelf (H) to Right Panel (B), Left Panel (C) and Back Panel (D) with Washers (Q) and M0.24"*0.60"Bolts (P). Hand tighten only.</p>
<p>B. </p> <p>C. </p> <p>D. </p> <p>H. </p> <p>P. </p> <p>Q. </p> <p>R. </p>	
6	<p>Place the item in the upright position. Attach the Side Door (J) to Door's Bottom Shelf (K) by using Washers (Q) and M0.24"*0.79"Bolts (O), M0.24"*1.38"Bolts (N). Hand tighten only.</p>
<p>J. </p> <p>K. </p> <p>N. </p> <p>O. </p> <p>Q. </p> <p>R. </p>	

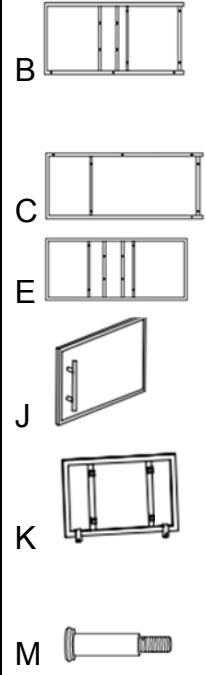
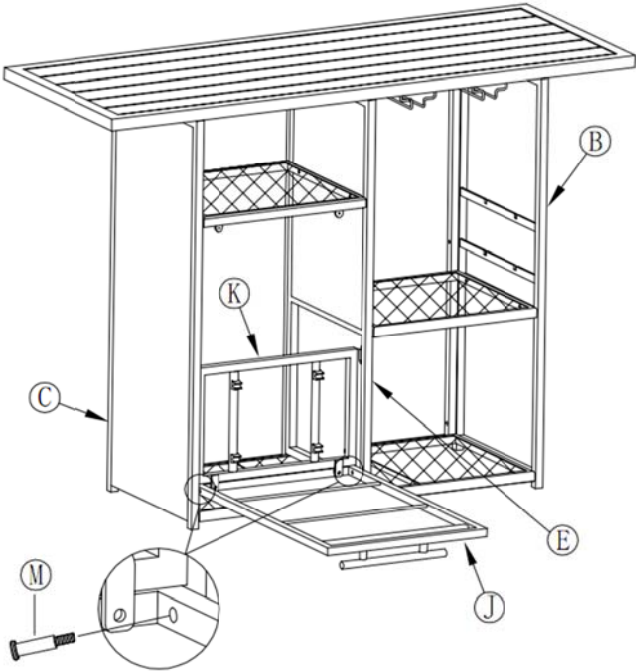
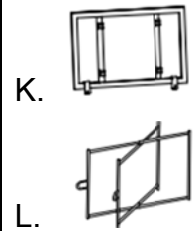
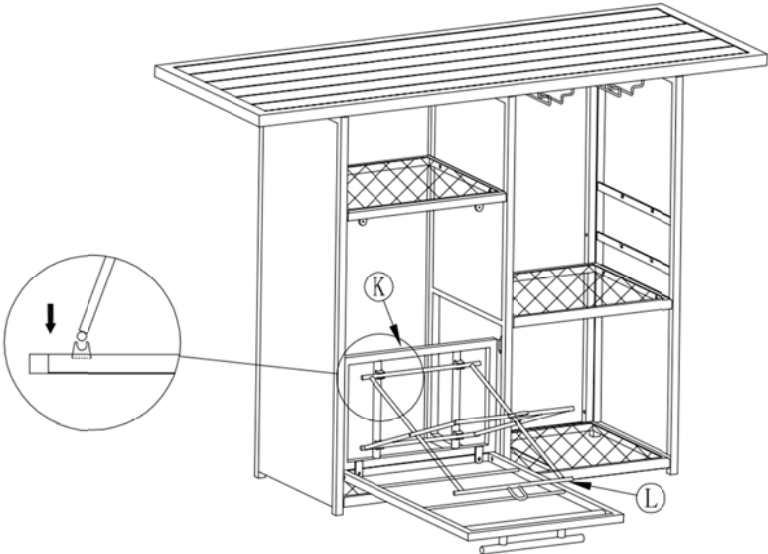
STEP	
7	Connect the Side Door (J) to Left panel (C) and Middle Panel (E) with M0.24"*0.47"Bolts (M). Hand tighten only.
	
8	Attach the Metal Frame (L) onto the Door's Bottom Shelf (K).
	

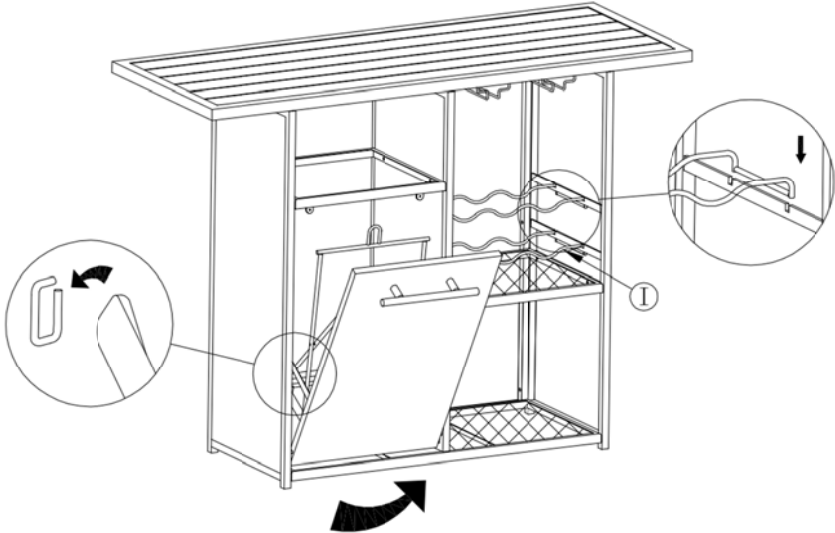
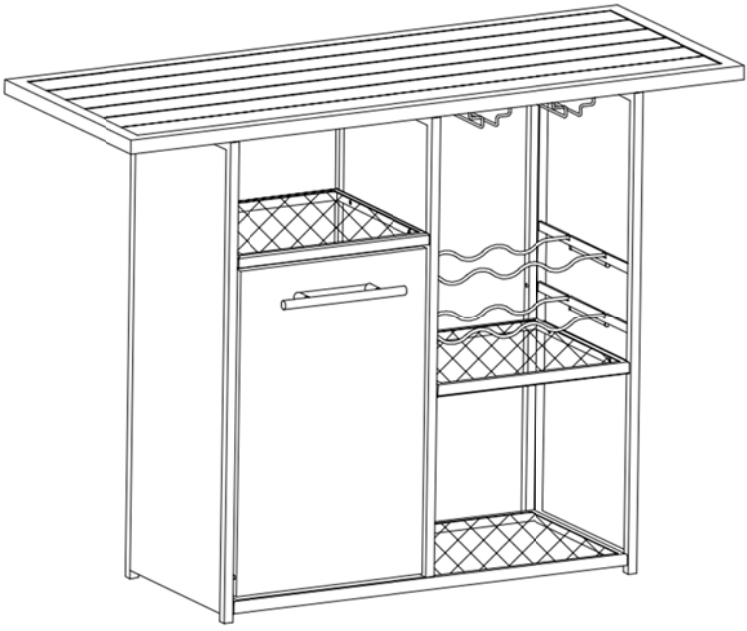
STEP	
9	Slip the Side Door's (J) ribbons onto the hooks on the Left Panel (C) and Middle Panel (E). Close the Side Door (J). Place the Bottle Rack (I) between Right Panel (B) and Middle Panel (E).
	
10	Use Allen Wrench (R) to tighten all bolts. Do not over tighten. Over tightening may strip bolts and washers. Now you have your new WICKER BAR.
	

Cleaning and Maintenance

- Clean with mild soap and water, rinse thoroughly, and dry completely. Do not use bleach, acid, or other solvents on this item.
- We recommend the use of furniture covers to protect this item when not in use.
- Inspect and tighten all bolts on a regular basis to ensure proper performance and safety.
- In order to prolong the life and beauty of your Wicker Bar Table, we recommend storing it in a dry and protected area during off season periods.



DIRECTIVES D'ASSEMBLAGE

BAR EN OSIER

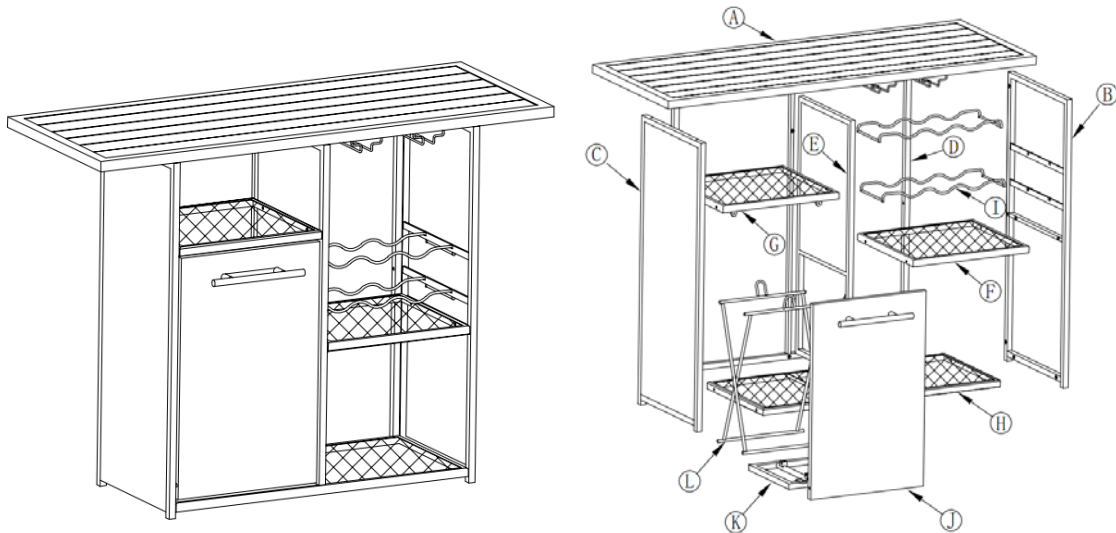

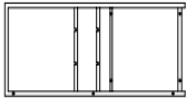
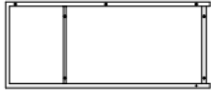

UGS N 68636371





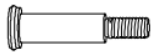

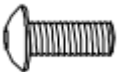



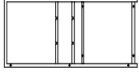
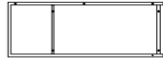



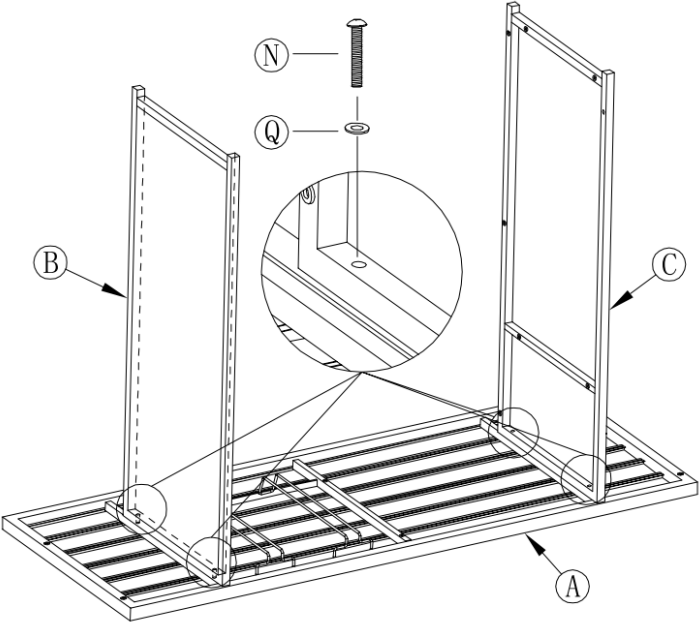
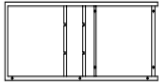
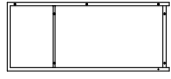



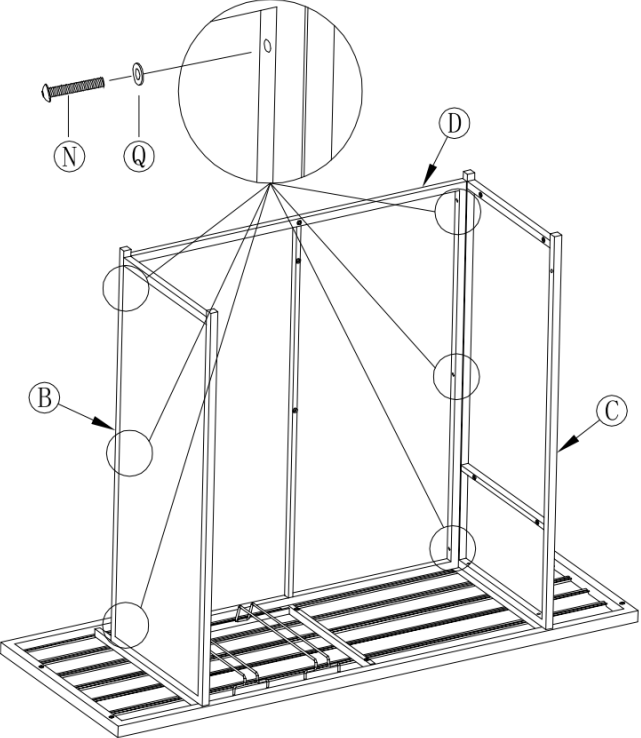

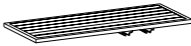

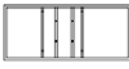

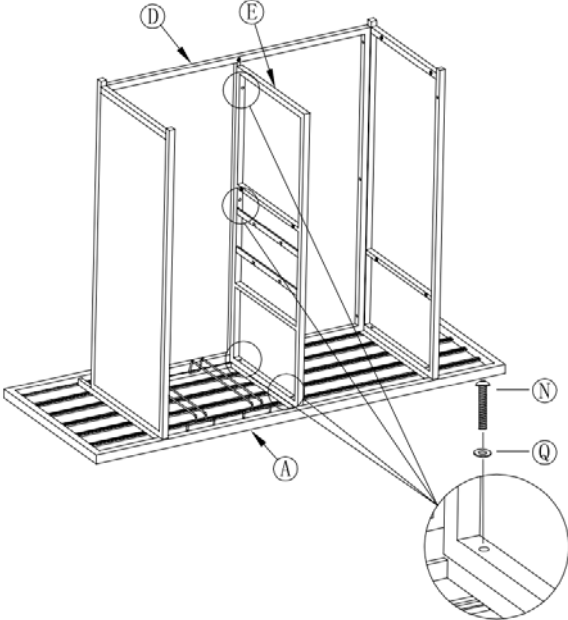

COMPOSANTES









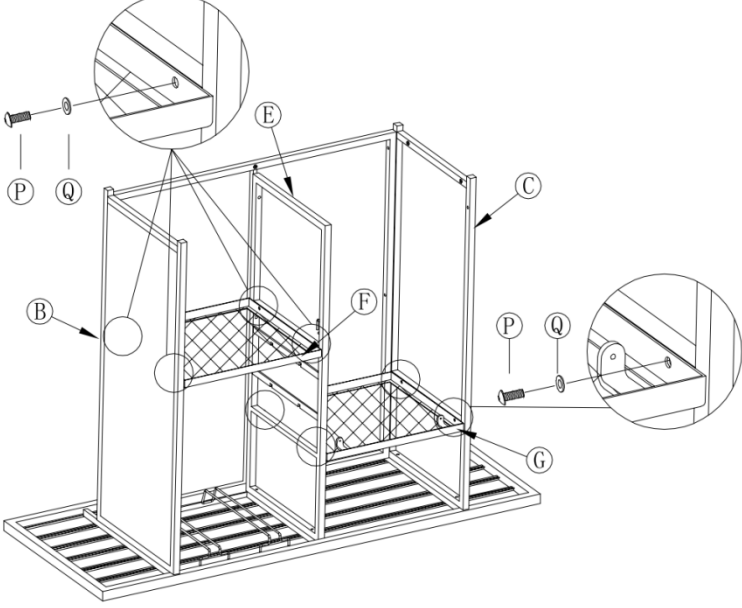



PIÈCE	FIGURE	DESCRIPTION	QTÉ
A		PLATEAU DE TABLE	1
B		PANNEAU DROITE	1
C		PANNEAU GAUCHE	1
D		PANNEAU ARRIÈRE	1
E		PANNEAU MILIEU	1

COMPOSANTES			
PIÈCE	FIGURE	DESCRIPTION	QTÉ
F		TABLETTE DROITE	1
G		TABLETTE GAUCHE	1
H		TABLETTE DU BAS	1
I		RÂTELIER À BOUTEILLES	2
J		PORTE LATÉRALE	1
K		TABLETTE INFÉRIEURE DE PORTE	1
L		CADRE EN MÉTAL	1

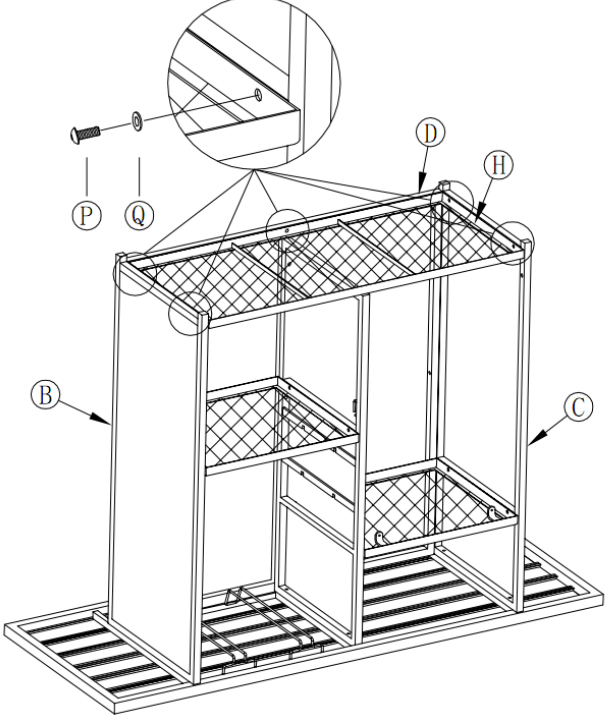
QUINCAILLERIE ET OUTILS			
M		BOULON M 0,24 po x 0,47 po	2
N		BOULON M 0,24 po x 1,38 po	15
O		BOULON 0,24 po x 0,79 po	2
P		BOULON 0,24 po x 0,6 po	13
Q		RONDELLE	30
R		CLÉ HEXAGONALE	1

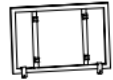
Étape	
<p data-bbox="288 304 304 331">1</p>	<p data-bbox="477 241 1458 398">Placer le plateau de table (A) à l'envers sur une surface non abrasive. Fixer le panneau droite (B) et le panneau gauche (C) au plateau de table (A) en insérant les rondelles (Q) et les boulons M 0,24 po x 1,38 po (N). Serrer à la main uniquement.</p>
<p data-bbox="145 412 177 439">A.</p>  <p data-bbox="145 521 177 548">B.</p>  <p data-bbox="145 651 177 678">C.</p>  <p data-bbox="145 781 177 808">N.</p>  <p data-bbox="145 853 177 880">Q.</p>  <p data-bbox="145 943 177 969">R.</p> 	 <p data-bbox="520 667 552 694">B</p> <p data-bbox="743 461 775 488">N</p> <p data-bbox="743 539 775 566">Q</p> <p data-bbox="1142 667 1174 694">C</p> <p data-bbox="1046 987 1078 1014">A</p>
<p data-bbox="288 1120 304 1146">2</p>	<p data-bbox="477 1075 1458 1187">Fixer le panneau arrière (D) au panneau droite (B) et le panneau gauche (C) en utilisant les rondelles (Q) et les boulons M 0,24 po x 1,38 po (N). Serrer à la main uniquement.</p>
<p data-bbox="145 1373 177 1400">B.</p>  <p data-bbox="145 1491 177 1518">C.</p>  <p data-bbox="145 1630 177 1657">D.</p>  <p data-bbox="145 1704 177 1731">N.</p>  <p data-bbox="145 1783 177 1809">Q.</p>  <p data-bbox="145 1872 177 1899">R.</p> 	 <p data-bbox="544 1361 576 1388">N</p> <p data-bbox="616 1361 647 1388">Q</p> <p data-bbox="935 1335 967 1361">D</p> <p data-bbox="520 1608 552 1635">B</p> <p data-bbox="1078 1626 1110 1653">C</p>

ÉTAPE	
<p>3</p>	<p>Fixer le panneau du milieu (E) au panneau arrière (D) et le plateau de table (C) en utilisant les rondelles (Q) et les boulons M 0,24 po x 1,38 po (N). Serrer à la main uniquement.</p>
<p>A. </p> <p>D. </p> <p>E. </p> <p>N. </p> <p>Q. </p> <p>R. </p>	
<p>4</p>	<p>Fixer la tablette droite (F) au panneau droit (B) et le panneau du milieu (E) en utilisant les rondelles (Q) et les boulons M 0,24 po x 0,60 po (N). Fixer la tablette gauche (G) au panneau gauche (C) et le panneau du milieu (E) en utilisant les rondelles (Q) et les boulons M 0,24 po x 0,60 po (P). Serrer à la main uniquement.</p>
<p>B. </p> <p>C. </p> <p>E. </p> <p>F. </p> <p>H. </p> <p>G. </p> <p>P. </p> <p>Q. </p> <p>R. </p>	

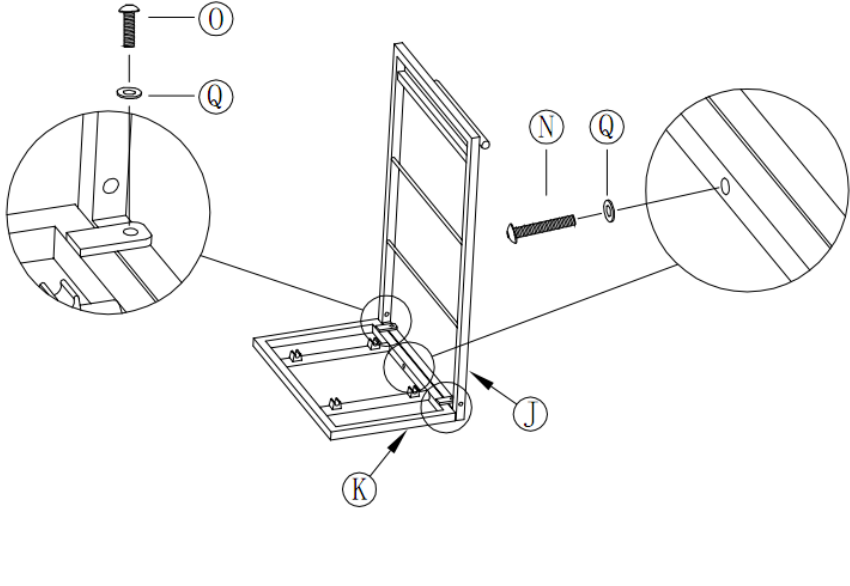
ÉTAPE	
5	<p>Fixer la tablette inférieure (H) au panneau droit (B), panneau de gauche (C) et au panneau arrière (D) en utilisant les rondelles (Q) et les boulons M 0,24 po x 0,60 po (P). Serrer à la main uniquement.</p>
<p>B. </p> <p>C. </p> <p>D. </p> <p>H. </p> <p>P. </p> <p>Q. </p> <p>R. </p>	
6	<p>Mettre l'article debout.</p> <p>Fixer la Porte latérale (J) à la tablette inférieure de la porte (K) à l'aide des rondelles (Q) et des boulons M 0,24 po x 0,79 po (O), M 0,24 po x 1,38 po (N). Serrer à la main uniquement.</p>
<p>J. </p> <p>K. </p> <p>N. </p> <p>O. </p> <p>Q. </p> <p>R. </p>	

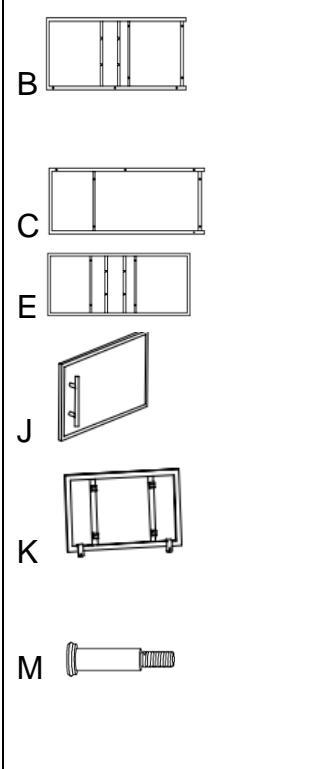
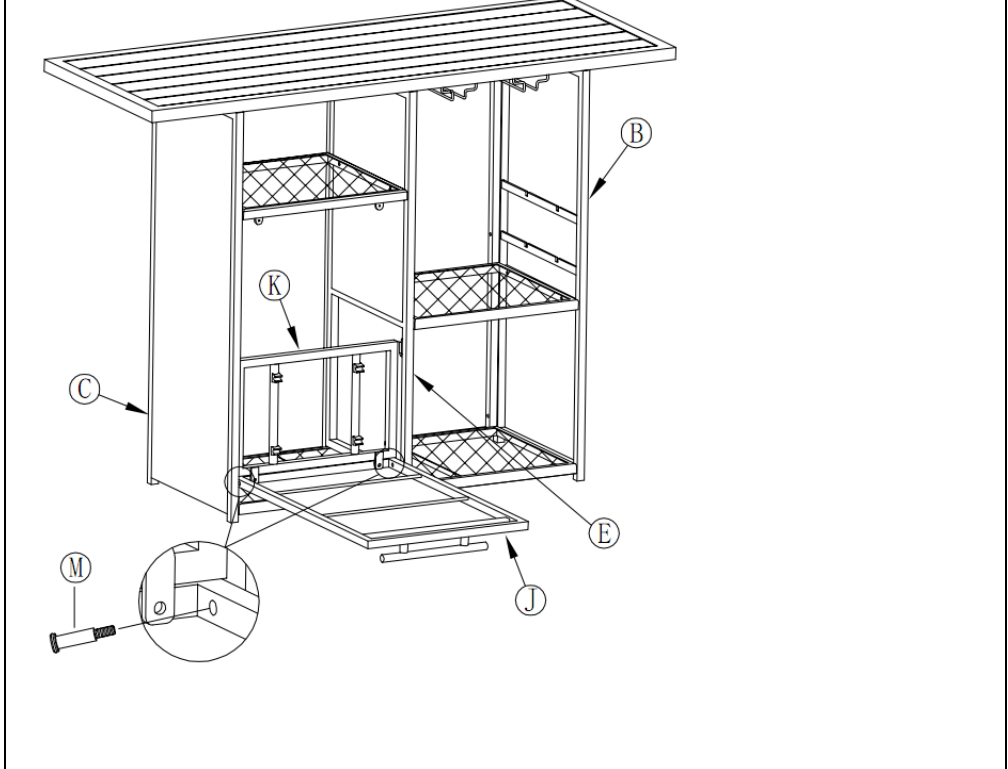
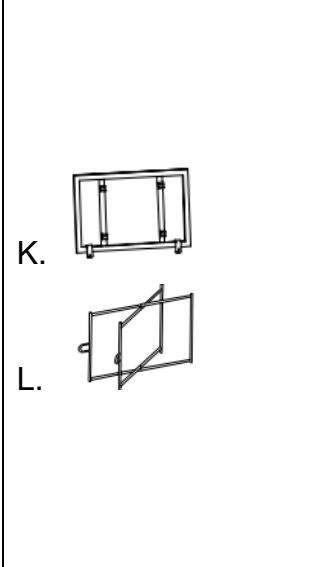
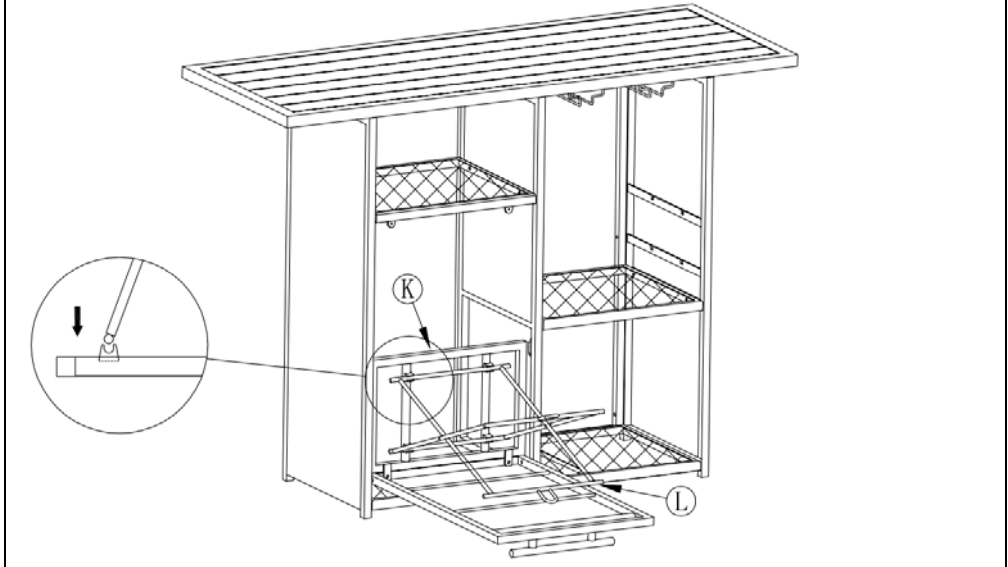
ÉTAPE	
7	Raccorder la porte latérale (J) au panneau gauche (C) et le panneau du milieu (E) avec des boulons M 0,24 po x 0,47 po (M). Serrer à la main uniquement.
 <p>B</p> <p>C</p> <p>E</p> <p>J</p> <p>K</p> <p>M</p>	
8	Fixer le cadre métallique (L) à la tablette inférieure de la porte (K).
 <p>K.</p> <p>L.</p>	

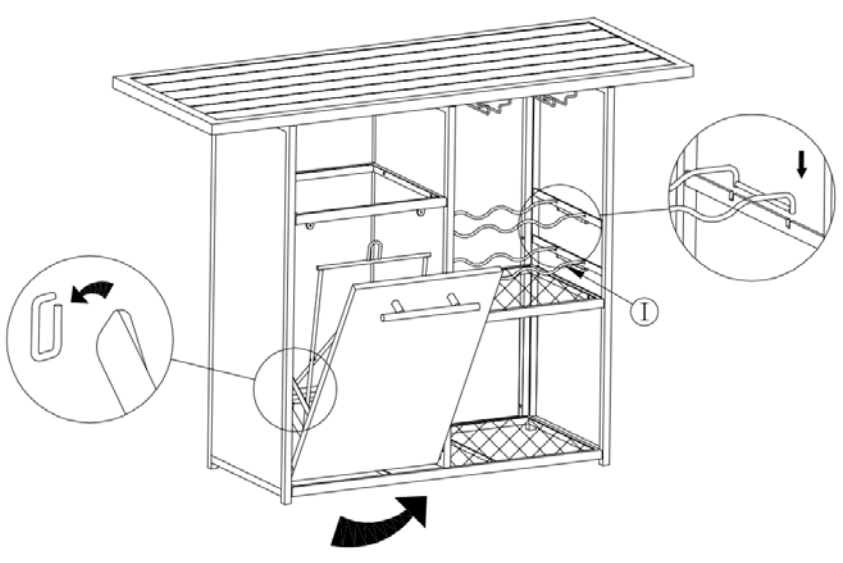
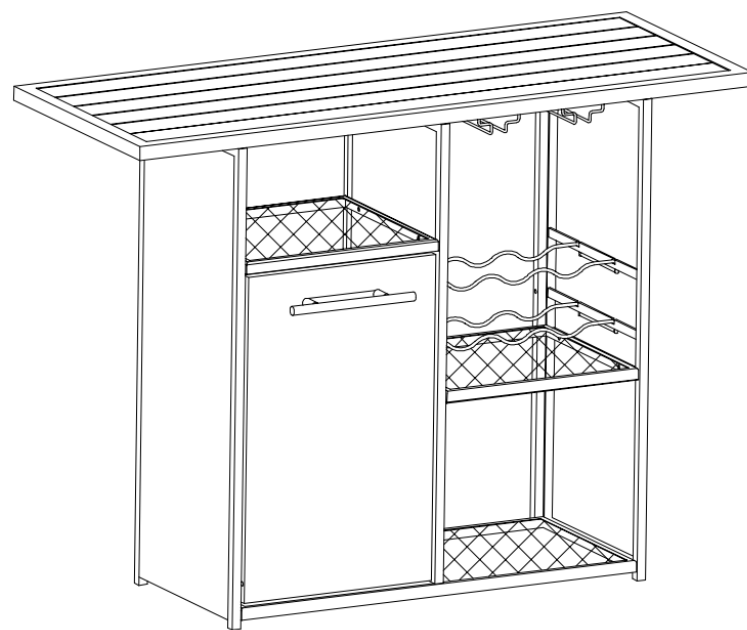
ÉTAPE	
9	<p>Glisser les rubans de la porte latérale (J) sur les crochets du panneau gauche (C) et le panneau du milieu (E). Fermer la porte latérale (J). Placer le râtelier à bouteille (I) entre le panneau droit (B) et le panneau du milieu (E).</p>
	
10	<p>Utiliser une clé hexagonale (R) pour serrer tous les boulons. Ne pas trop serrer. Trop serrer risque de détruire le pas des boulons et des rondelles. Vous avez maintenant un nouveau BAR EN OSIER.</p>
	

Nettoyage et entretien

- Nettoyer avec du savon doux et de l'eau, rincer soigneusement et bien sécher. Ne pas utiliser de javellisant, d'acide ou autres solvants sur cet article.
- Nous recommandons l'usage de protections à meubles pour protéger cet article entre les utilisations.
- Vérifier l'état et serrer tous les boulons régulièrement pour garantir l'utilisation et la sécurité.
- Afin de prolonger la durée et la beauté de votre table de bar en osier, nous vous recommandons de la ranger dans un endroit sec et protégé pendant les périodes hors saison.



INSTRUCCIONES DE ENSAMBLADO

MESA DE BAR DE MIMBRE

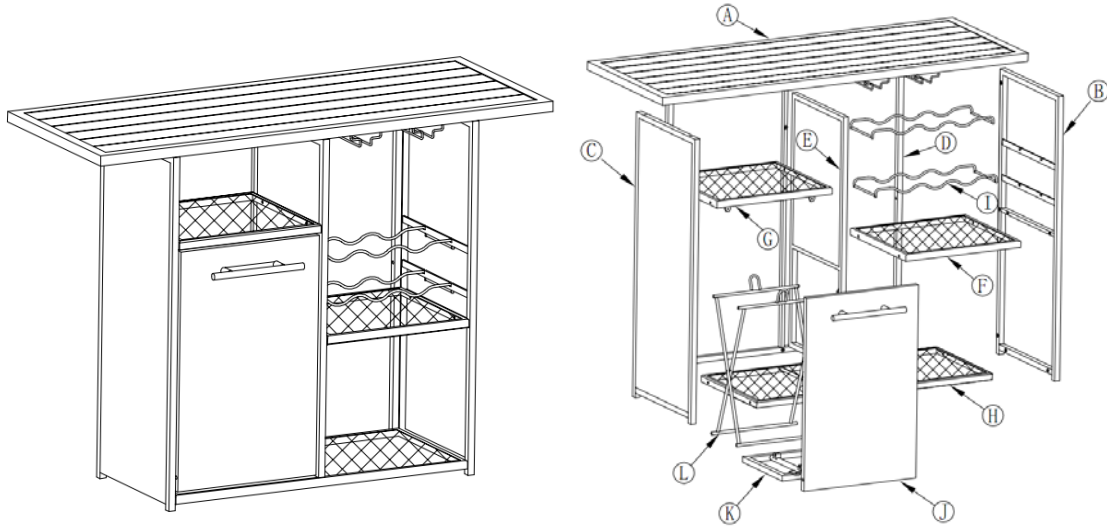





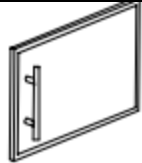
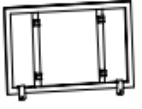
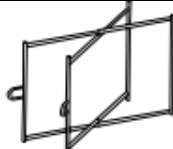



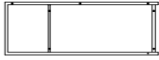

n. de SKU: 68636371



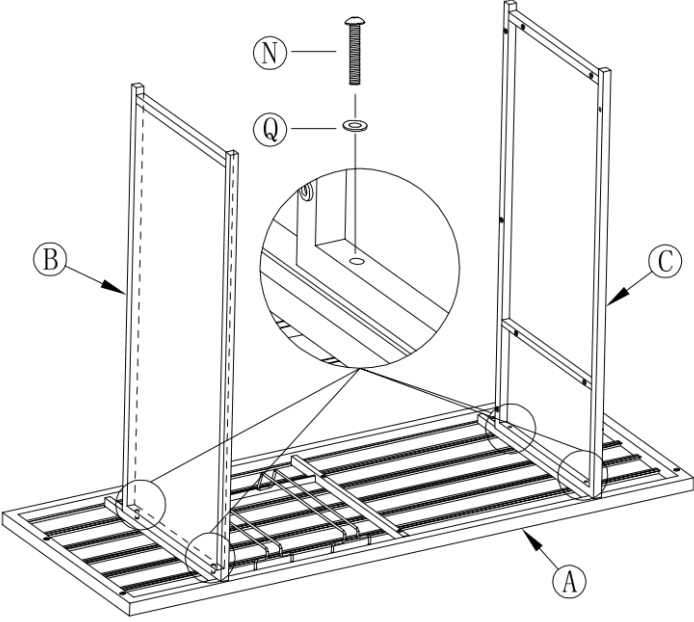

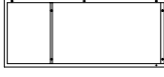



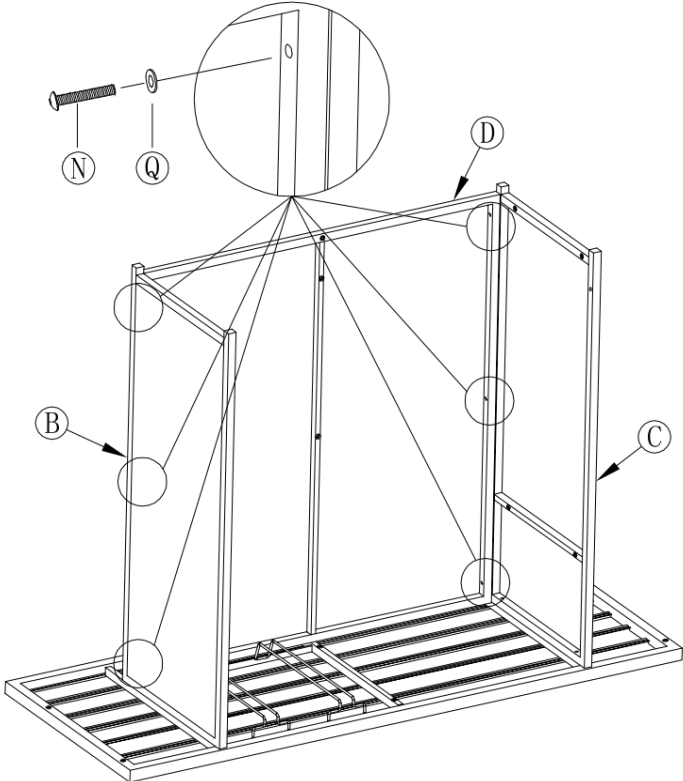







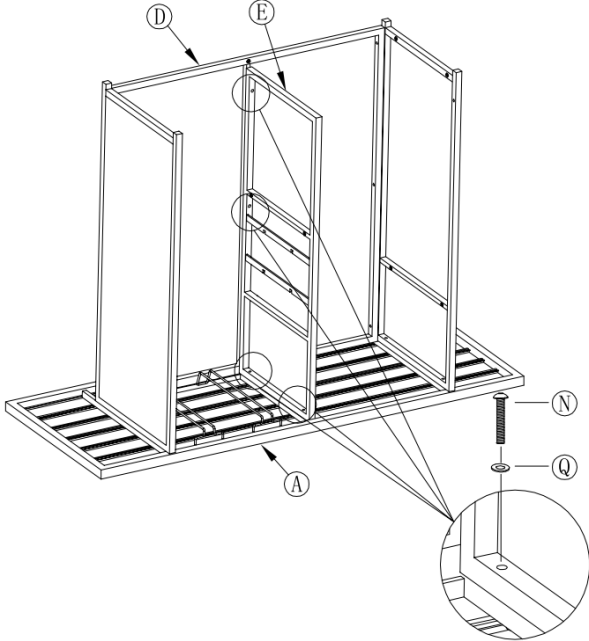
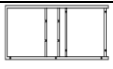
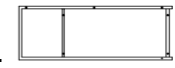
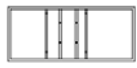





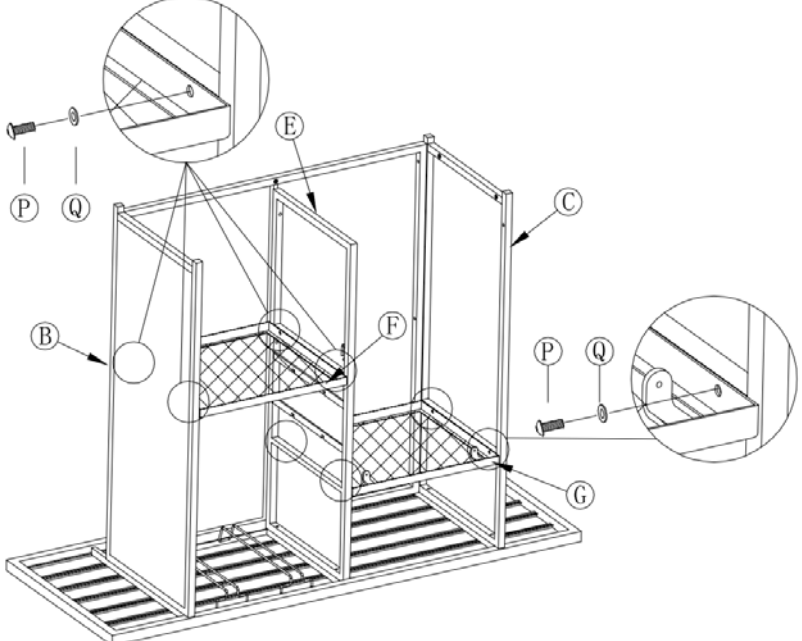



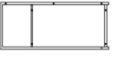

COMPONENTES			
PARTE	FIGURA	DESCRIPCIÓN	CANTIDAD
A		TABLERO	1
B		PANEL DERECHO	1
C		PANEL IZQUIERDO	1
D		PANEL POSTERIOR	1
E		PANEL CENTRAL	1

COMPONENTES			
PARTE	FIGURA	DESCRIPCIÓN	CANTIDAD
F		ESTANTE DERECHO	1
G		ESTANTE IZQUIERDO	1
H		ESTANTE INFERIOR	1
I		PORTABOTELLAS	2
J		PUERTA LATERAL	1
K		ESTANTE INFERIOR DE LA PUERTA	1
L		MARCO DE METAL	1

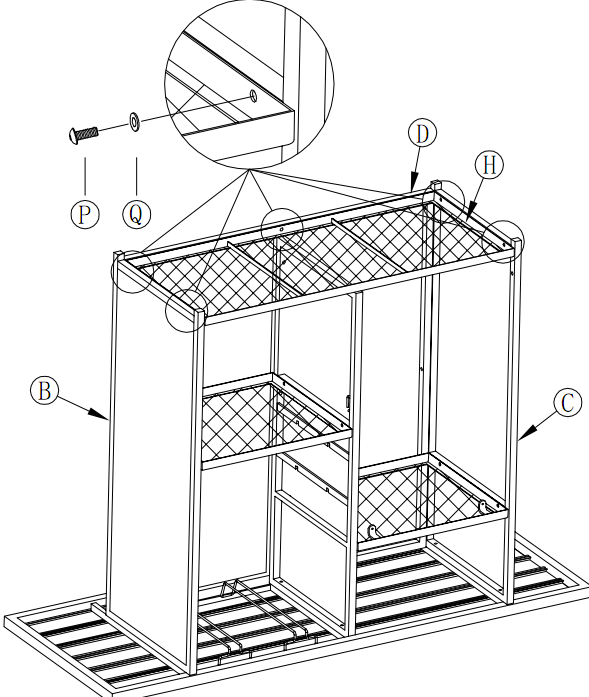
MATERIALES Y HERRAMIENTAS			
M		PERNO DE M0.24"*0.47"	2
N		PERNO DE M0.24"*1.38"	15
O		PERNO DE 0.24"*0.79"	2
P		PERNO DE 0.24"*0.6"	13
Q		ARANDELA	30
R		LLAVE ALLEN	1

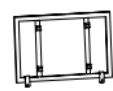
PASO	
1	Coloque el tablero (A) boca abajo sobre una superficie no abrasiva. Fije el panel derecho (B) y el panel izquierdo (C) al tablero (A) insertando arandelas (Q) y pernos de M0.24"*1.38" (N). Solo ajustar a mano.
<p>A. </p> <p>B. </p> <p>C. </p> <p>N. </p> <p>Q. </p> <p>R. </p>	
2	Fije el panel posterior (D) al panel derecho (B) y al panel izquierdo (C) usando arandelas (Q) y pernos de M0.24"*1.38" (N). Solo ajustar a mano.
<p>B. </p> <p>C. </p> <p>D. </p> <p>N. </p> <p>Q. </p> <p>R. </p>	

PASO	
3	Fije el panel central (E) al panel posterior (D) y al tablero (A) usando arandelas (Q) y pernos de M0.24"*1.38" (N). Solo ajustar a mano.
<p>A. </p> <p>D. </p> <p>E. </p> <p>N. </p> <p>Q. </p> <p>R. </p>	
4	Fije el estante derecho (F) al panel derecho (B) y al panel central (E) usando arandelas (Q) y pernos de M0.24"*0.60" (P). Fije el estante izquierdo (G) al panel izquierdo (C) y al panel central (E) usando arandelas (Q) y pernos de M0.24"*0.60" (P). Solo ajustar a mano.
<p>B. </p> <p>C. </p> <p>E. </p> <p>F. </p> <p>H. </p> <p>G. </p> <p>P. </p> <p>Q. </p> <p>R. </p>	

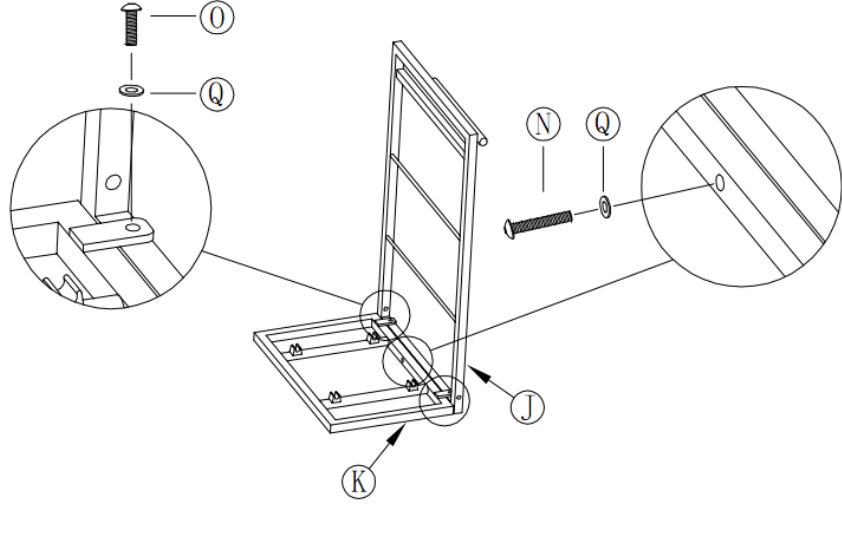
PASO	
5	<p>Fije el estante inferior (H) al panel derecho (B), panel izquierdo (C) y al panel posterior (D) con arandelas (Q) y pernos de M0.24"×0.60" (P). Solo ajustar a mano.</p>
<p>B. </p> <p>C. </p> <p>D. </p> <p>H. </p> <p>P. </p> <p>Q. </p> <p>R. </p>	
6	<p>Coloque el artículo en la posición recta. Fije la puerta lateral (J) al estante inferior de la puerta (K) usando arandelas (Q), pernos de M0.24"×0.79" (O) y pernos de M0.24"×1.38" (N). Solo ajustar a mano.</p>
<p>J. </p> <p>K. </p> <p>N. </p> <p>O. </p> <p>Q. </p> <p>R. </p>	

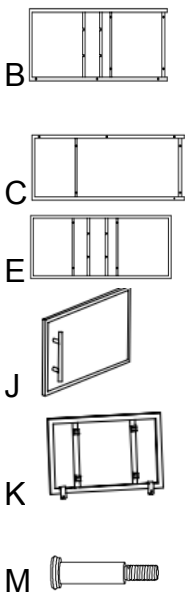
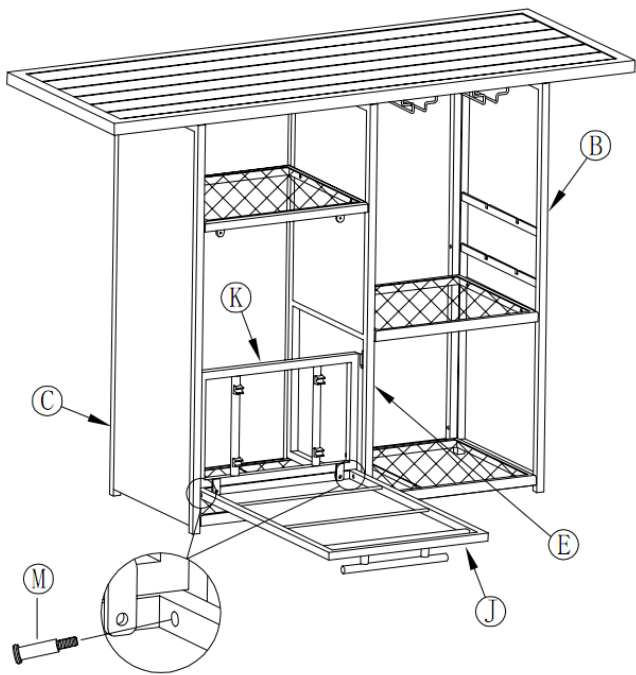
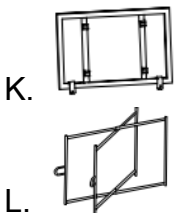
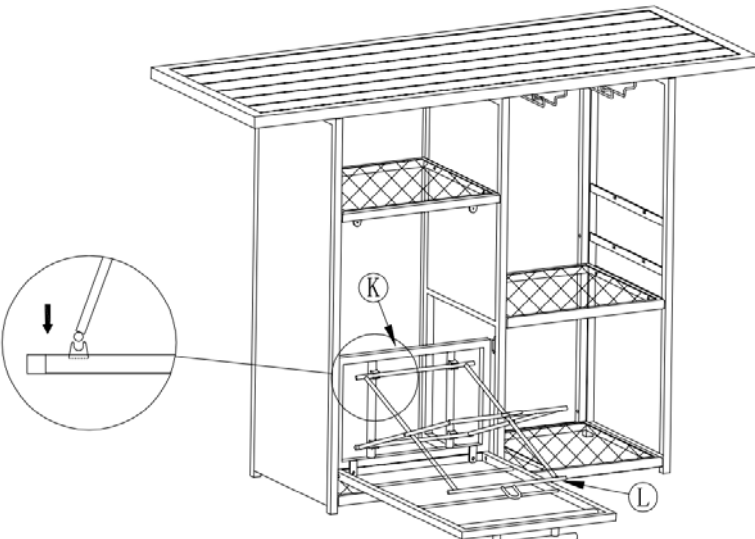
PASO	
7	Fije la puerta lateral (J) al panel izquierdo (C) y al panel central (E) con pernos de M0.24"×0.47" (M). Solo ajustar a mano.
 <p>B</p> <p>C</p> <p>E</p> <p>J</p> <p>K</p> <p>M</p>	
8	Fije el marco de metal (L) en el estante inferior de la puerta (K).
 <p>K.</p> <p>L.</p>	

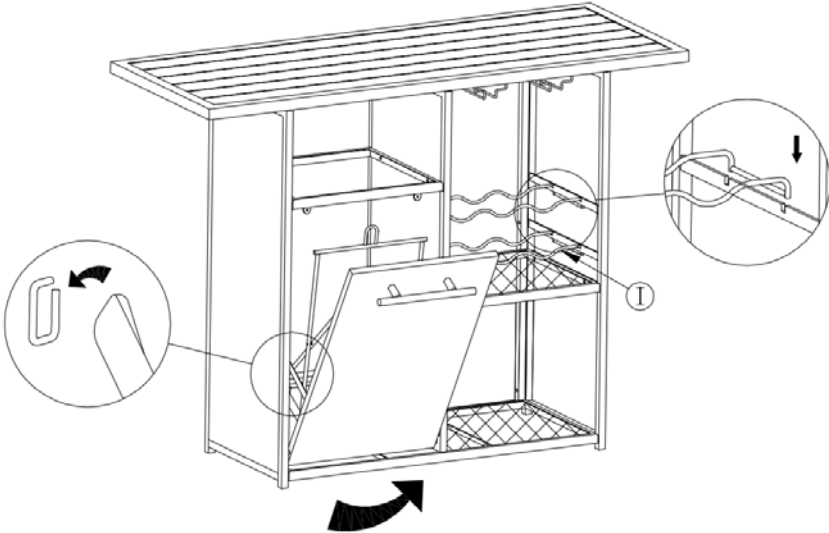
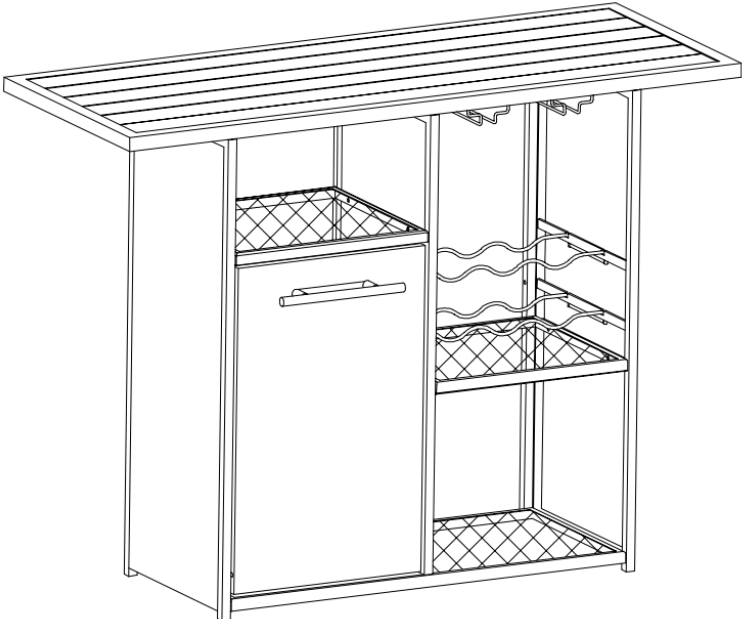
PASO	
9	<p>Deslice las bandas de la puerta lateral (J) en los ganchos del panel izquierdo (C) y del panel central (E). Cierre la puerta lateral (J). Coloque el portabotellas (I) entre el panel derecho (B) y el panel central (E).</p>
	
10	<p>Use la llave Allen (R) para ajustar todos los pernos. No ajuste demasiado. Si ajusta demasiado puede estropear los pernos y las arandelas. Ahora tiene su nueva MESA DE BAR DE MIMBRE.</p>
	

Limpieza y Mantenimiento

- Limpie con jabón suave y agua, enjuague bien y seque por completo. No use lejía, ácido u otros solventes en este artículo.
- Se recomienda el uso de cubiertas para muebles para proteger este artículo cuando no esté en uso.
- Inspeccione y ajuste todos los pernos regularmente para asegurar la seguridad y el buen funcionamiento.
- Con el fin de prolongar la vida útil y belleza de su Mesa de Bar de Mimbre, recomendamos que la guarde en un área seca y protegida durante los períodos fuera de temporada.

Warning!

- Do not let any sharp objects touch or rub the surface of the product.
- When assembling, do not let children play around the working area.
- Please confirm all parts are correct before starting the assembly process.
- Do not tighten all bolts and screws completely until the entire unit has been assembled and set up.
- Use only the hex wrench provided. **DO NOT USE POWER TOOLS.**

Power tools can overtighten screws and strip threads

For each screw:

1. The washer must be next to the tube.
2. Tighten each screw until you meet resistance and spacer begins to push into the tube.
3. Tighten one additional full rotation. **DO NOT OVERTIGHTEN.**

Atención!

- No permita que ningún objeto afilado roce o toque la superficie del producto.
- No permita que hayan niños jugando alrededor mientras realiza la instalación.
- Por favor revise que todas las partes estén correctas antes de empezar con la instalación.
- No asegure los pernos y tornillos hasta que la unidad completa haya sido instalada y los ajustes se hayan establecido.
- Use solamente el Destornillador de cabeza hexagonal incluido.

NO UTILICE HERRAMIENTAS ELÉCTRICAS.

Las herramientas eléctricas pueden ajustar los tornillos demasiado y rasgar cables.

Para los tornillos:

1. Rondelle deben encontrarse al lado de la tuda.
2. Asegure cada tornillo hasta que sienta resistencia y los Espaciador empiecen a presionar la tuda.
3. Asegure hasta un poco más de lo aceptado. **No asegure los tornillos demasiado.**

Attention

- Ne laissez pas tout objet pointu de toucher ou de frotter la surface du produit.
- Lors de l'assemblage, de ne pas laisser les enfants jouer près de l'aire de travail.
- Veuillez confirmer que tous les éléments sont exacts avant d'entamer le processus d'assemblage.
- Ne pas serrer tous les boulons et vis complètement jusqu'à l'unité entière a été assemblé et mis en place.
- Utiliser les outils fournis. **Ne pas utiliser des outils électriques.**

Outils électriques peuvent renforcer des fils vis et bandes.

Pour chaque vis:

1. Arandela doit être à côté du tube.
2. Renforcer la résistance et chaque baiser jusqu'à ce que le espaceur commence à pousser dans le tube.
3. Une rotation supplémentaire. **Ne pas trop serrer.**