

Item # 0000 000 000
Model # FRS70550-ST

HAMPTON BAY®

USE AND CARE GUIDE

STEEL WOVEN EGG CHAT SET

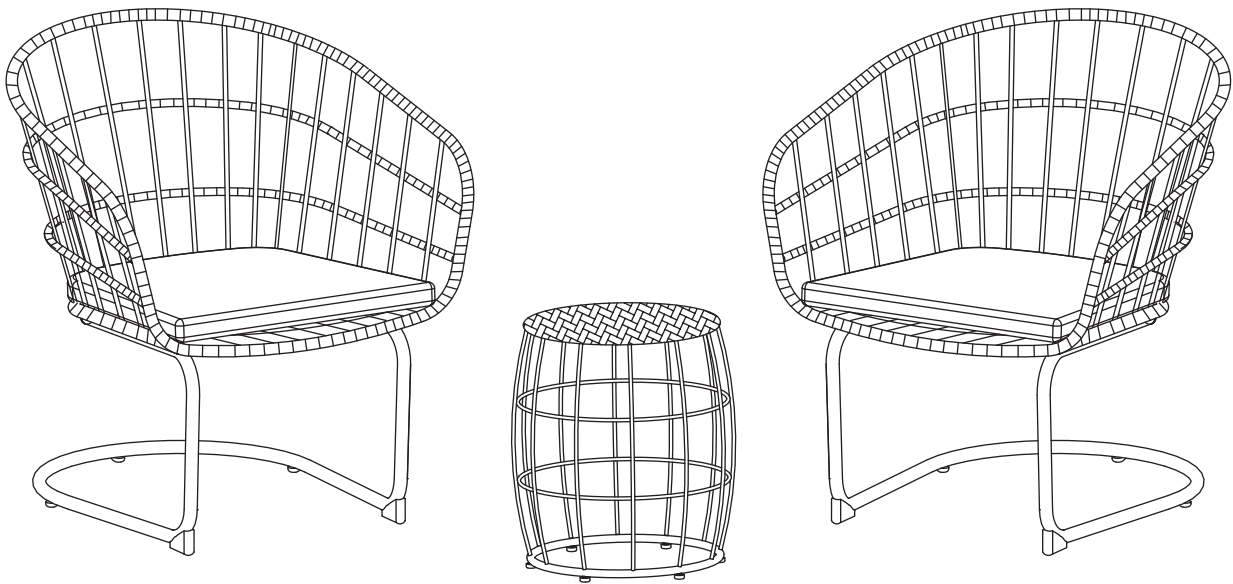

Questions, problems, missing parts? Before returning to the store,
call Hampton Bay Customer Service
8 a.m. - 7 p.m., EST, Monday – Friday, 9 a.m. – 6 p.m., EST, Saturday

1-855-HD-HAMPTON

HOMEDEPOT.CA

THANK YOU

We appreciate the trust and confidence you have placed in Hampton Bay through the purchase of this set. We strive to continually create quality products designed to enhance your home. Visit us online to see our full line of products available for your home improvement needs. Thank you for choosing Hampton Bay!

Table of Contents

Table of Contents	2	Pre-Assembly	3
Important Safety Instructions	2	Planning Assembly	3
Save These Instructions	2	Hardware Included	3
Read All Instructions Before Use	2	Chair Package Contents	4
Warranty	3	Table Package Contents	4
What is covered	3	Assembly	5
What is not covered	3	Care and Cleaning	6

Important Safety Instructions

SAVE THESE INSTRUCTIONS



WARNING: THIS SET IS MADE FOR THE EXPLICIT PURPOSE OF PROVIDING OUTDOOR FUNCTIONS AND IS NOT TO BE USED AS A TOY. THIS PRODUCT IS INTENDED FOR NORMAL OUTDOOR USE; HOWEVER, THE MANUFACTURER RECOMMENDS STORING AND/OR COVERING THIS PRODUCT WHEN ANY FORMIDABLE/SEVERE WEATHER IS APPROACHING.



WARNING: DO NOT LOCATE THIS PRODUCT NEAR OPEN FLAMES. DO NOT USE THIS PRODUCT AS A SUPPORT. DO NOT SHAKE, LEAN OR CLIMB ON THE PRODUCT. CHILDREN UNDER THE AGE OF 10, NEAR THE PRODUCT, SHOULD BE SUPERVISED BY A COMPETENT ADULT AT ALL TIMES. THIS PRODUCT IS NOT INTENDED FOR COMMERCIAL USE AND WILL VOID THE WARRANTY.

READ ALL INSTRUCTIONS BEFORE USE

To reduce the risk of injury to persons:

1. Close supervision is necessary when this furnishing is used by or near children, or disabled persons, if applicable.
2. Use this furnishing only for its intended use as described in these instructions. Do not use attachments not recommended by the manufacturer.
3. Do not move the chair while it is occupied. Failure to obey this caution could result in injury.



CAUTION: When not in use, secure the product in a cool and covered location.



CAUTION: Do not locate the product near any heat sources.



WARNING: Weight limit for the chair is 250lbs (113.39Kg) for each seat.



WARNING: Please keep children out of the assembly area before assembly.



WARNING: This chair unit is heavy, and may require two adults for safe assembly.



WARNING: Never use this product as a support. Do not shake, lean, or climb on the product at any time.



WARNING: Do not place heavy objects on the chair or table.

Warranty

2 YEAR FRAME AND 2 YEAR FABRIC LIMITED WARRANTY

WHAT IS COVERED

We warrant the frames to be free of manufacturing defects to the original purchaser for two years, and a two year limited warranty for the fabric.

WHAT IS NOT COVERED

It remains the customer's responsibility for freight and packaging charges to and from our service center. This warranty does not cover commercial use, hardware, acts of nature, fire, freezing and abusive use. In addition, purchased parts are not covered under this warranty. We reserve the right to make substitutions with similar merchandise, if the model in question is no longer in production.

Contact the Customer Service Team at 1-855-HD-HAMPTON or visit www.HOMEDEPOT.ca.

Pre-Assembly

PLANNING ASSEMBLY

Read all instructions before assembly.

To avoid damaging this product, assemble it on a soft, non-abrasive surface such as carpet or cardboard.



NOTE: More than one person may be required to assemble this product.

HARDWARE INCLUDED



NOTE: Hardware not shown to actual size.

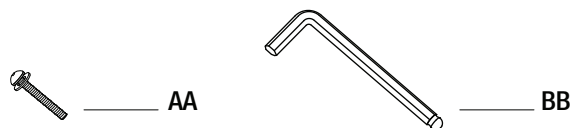

Part	Description	Quantity
AA	M6x35 Combination Bolt	8+1
BB	Hex Wrench	1

Pre-Assembly (continued)

CHAIR PACKAGE CONTENTS

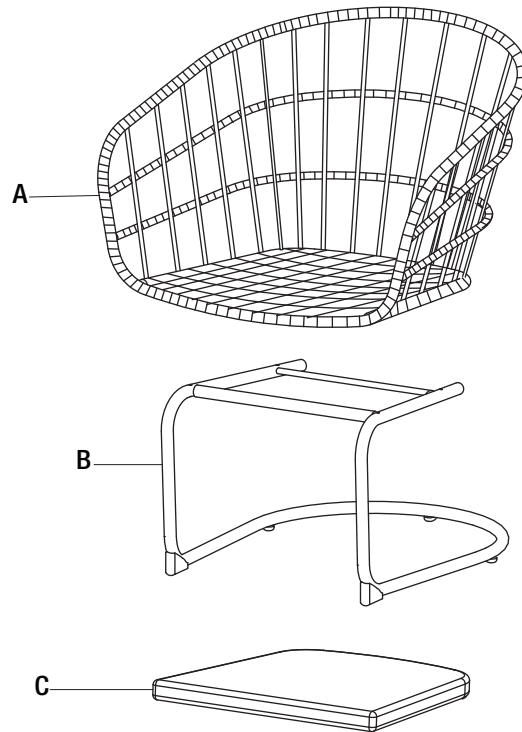

Part	Description	Quantity
A	Chair Frame	2
B	Chair Base	2
C	Seat Cushion	2

TABLE PACKAGE CONTENTS

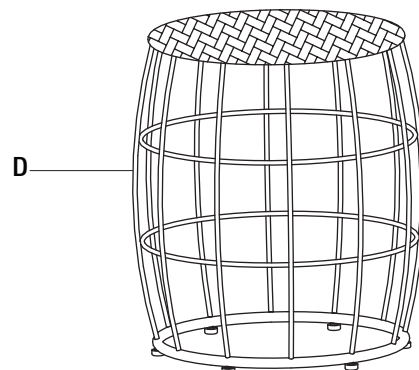

Part	Description	Quantity
D	Table	1

Assembly

1 Attaching The Chair Base To The Chair Frame

- Place the chair bucket (A) upside down on a soft surface.
- Attach the chair base (B) to the chair frame (A) using M6x35 combination bolts (AA).
- Once all of the bolts are in place, fully tighten the bolts using the hex wrench (BB).

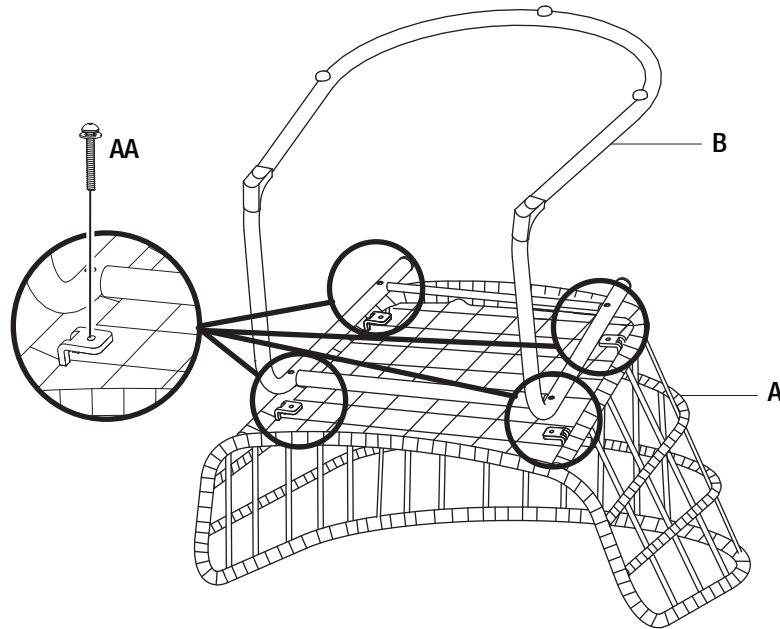

2 Checking The Chair

- Place the seat cushion (C) on to finish the assembly of the chair.
- Ensure all connections are secure before use.

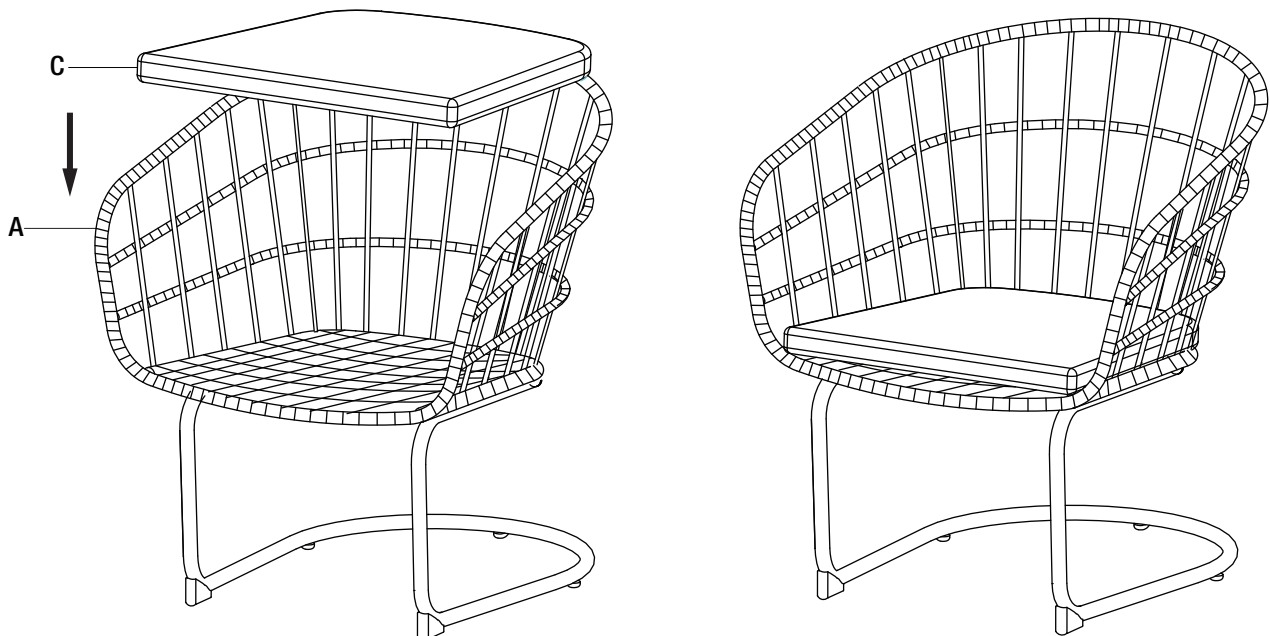

Care and Cleaning

- For best results, clean the frame and cushions with a damp cloth and dry thoroughly. This will help prevent mildew by removing dirt particles that may accumulate.
- Do not clean with abrasive materials, bleach or solvents.
- Store the set in a dry sheltered place when not in use.
- Keep the set out of fire, extreme heat, freezing conditions, and inclement weather such as rain, hail, sleet, snow, or wind.

HAMPTON BAY[®]

Questions, problems, missing parts? Before returning to the store,
call Hampton Bay Customer Service
8 a.m. – 7 p.m., EST, Monday – Friday, 9 a.m. – 6 p.m., EST, Saturday

1-855-HD-HAMPTON

HAMPTONBAY.CA

Retain this manual for future use.

For certification use only
Factory Chair ID# FRS70550
Factory Table ID# FWS70430